



# GT Classic Garden Tractor

Model No. 73450—Serial No. 25000001 and Up

**Operator's Manual**



## Warning



The engine exhaust from this product contains chemicals known to the State of California to cause cancer, birth defects, or other reproductive harm.

**Important** This engine is not equipped with a spark arrester muffler. It is a violation of California Public Resource Code Section 4442 to use or operate this engine on any forest-covered, brush-covered or grass-covered land. Other states or federal areas may have similar laws.

This spark ignition system complies with Canadian ICES-002.

Ce système d'allumage par étincelle de véhicule est conforme à la norme NMB-002 du Canada.

The enclosed Engine Owner's Manual is supplied for information regarding The U.S. Environmental Protection Agency (EPA) and the California Emission Control Regulation of emission systems, maintenance and warranty.

Keep this engine Owner's Manual with your unit. Should this engine Owner's Manual become damaged or illegible, replace immediately. Replacements may be ordered through the engine manufacturer.

# Contents

	Page
Introduction .....	2
Safety .....	3
Safe Operating Practices .....	3
Toro Riding Mower Safety .....	5
Slope Chart .....	7
Safety and Instruction Decals .....	9
Gasoline and Oil .....	11
Recommended Gasoline .....	11
Using Stabilizer/Conditioner .....	11
Filling the Fuel Tank .....	11
Checking the Engine Oil Level .....	11
Setup .....	12
Loose Parts .....	12
Checking the Tire Pressure .....	12
Activating the Battery .....	12
Installing the Drawbar Hitch Pin .....	13
Attaching the Washer and Hairpin Cotter onto the Lift Bar .....	14
Checking the Wiring and Fasteners .....	14
Checking the Engine Oil .....	14

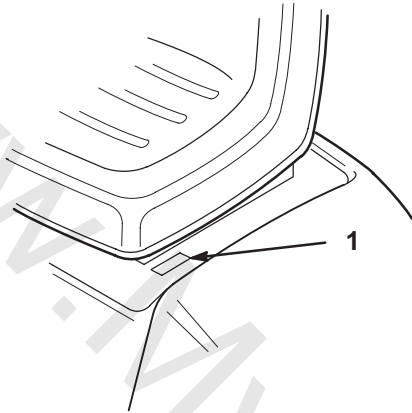
	Page
Learn to Operate the Tractor .....	14
Checking the Tractor Lubrication .....	14
Test Driving the Tractor .....	14
Checking the Safety System .....	14
Operation .....	15
Think Safety First .....	15
Controls .....	15
Using the Parking Brake .....	15
Starting and Stopping the Engine .....	15
Operating the Power Take Off (PTO) .....	16
Instruments .....	16
Indicator Lights .....	17
Checking the Safety Interlock System .....	17
Driving Forward or Backward .....	19
Selecting the Ground Speeds .....	19
Stopping the Machine .....	20
Using the Attachment Lift Lever .....	20
Adjusting the Dial-A-Height .....	20
Positioning the Seat .....	20
Using the Lights .....	21
Installing PTO Belt .....	21
Maintenance .....	22
Recommended Maintenance Schedule .....	22
Servicing the Air Cleaner .....	23
Servicing the Engine Oil .....	24
Servicing the Spark Plug .....	25
Greasing and Lubrication .....	26
Checking the Tire Pressure .....	27
Cleaning Engine Cooling Systems .....	27
Servicing the Brake .....	27
Maintaining the Front Wheel Toe-In .....	28
Servicing the Fuel Tank .....	28
Servicing the Transaxle Fluid .....	29
Servicing the Headlights .....	30
Servicing the Taillights .....	30
Servicing the Battery .....	30
Servicing the Fuse .....	33
Wiring Diagram .....	34
Cleaning and Storage .....	35
Troubleshooting .....	36
The Toro Total Coverage Guarantee .....	40

# Introduction

Read this manual carefully to learn how to operate and maintain your product properly. The information in this manual can help you and others avoid injury and product damage. Although Toro designs and produces safe products, you are responsible for operating the product properly and safely.

Contact us at [www.Toro.com](http://www.Toro.com)  
All Rights Reserved  
Printed in the USA

Whenever you need service, genuine Toro parts, or additional information, contact an Authorized Service Dealer or Toro Customer Service and have the model and serial numbers of your product ready. Figure 1 illustrates the location of the model and serial numbers on the product.



m-2345

**Figure 1**

1. Location of the model and serial numbers

Write the product model and serial numbers in the space below:

<b>Model No.</b> _____
<b>Serial No.</b> _____

This manual identifies potential hazards and has special safety messages that help you and others avoid personal injury and even death. **Danger**, **Warning**, and **Caution** are signal words used to identify the level of hazard. However, regardless of the hazard, be extremely careful.

**Danger** signals an extreme hazard that *will* cause serious injury or death if you do not follow the recommended precautions.

**Warning** signals a hazard that *may* cause serious injury or death if you do not follow the recommended precautions.

**Caution** signals a hazard that may cause minor or moderate injury if you do not follow the recommended precautions.

This manual uses two other words to highlight information. **Important** calls attention to special mechanical information and **Note** emphasizes general information worthy of special attention.

# Safety

**This machine meets or exceeds the B71.1–2003 specifications of the American National Standards Institute, in effect at the time of production. However, improper use or maintenance by the operator or owner can result in injury. To reduce the potential for injury, comply with these safety instructions and always pay attention to the safety alert symbol, which means CAUTION, WARNING, or DANGER—“personal safety instruction.” Failure to comply with the instruction may result in personal injury or death.**

## Safe Operating Practices

The following instructions are from ANSI standard B71.1—2003.

This product is capable of amputating hands and feet and throwing objects. Always follow all safety instructions to avoid serious injury or death.

## General Operation

- Read, understand, and follow all instructions in the operator’s manual and on the machine before starting.
- Do not place hands or feet near rotating parts or under the machine. Keep clear of the discharge opening at all times.
- Allow only responsible adults who are familiar with the instructions to operate the machine.
- Clear the area of objects such as rocks, toys, wire, etc., which could be picked up and thrown by the blade.
- Be sure the area is clear of other people before mowing. Stop the machine if anyone enters the area.
- Never carry passengers.
- Do not mow in reverse unless absolutely necessary. Always look down and behind before and while backing up.
- Never direct discharged material toward anyone. Avoid discharging material against a wall or obstruction. Material may ricochet back toward the operator. Stop the blade(s) when crossing gravel surfaces.
- Do not operate the mower without either the entire grass catcher, discharge guard or other safety devices in place and working.
- Slow down before turning.
- Never leave a running machine unattended. Always turn off blades, set parking brake, stop engine, and remove key before dismounting.

- Disengage blades when not mowing. Stop the engine and wait for all parts to come to a complete stop before cleaning the machine, removing the grass catcher or unclogging the discharge chute.
- Operate the machine only in daylight or good artificial light.
- Do not operate the machine while under the influence of alcohol or drugs.
- Watch for traffic when operating near or crossing roadways.
- Use extra care when loading or unloading the machine into a trailer or truck.
- Always wear safety goggles or safety glasses with side shields when operating mower.
- Data indicates that operators, age 60 years and above, are involved in a large percentage of riding mower-related injuries. These operators should evaluate their ability to operate the riding mower safely enough to protect themselves and others from serious injury.
- Always follow the recommendations for wheel weights or counterweights.

## Slope Operation

Slopes are a major factor related to loss-of-control and tip-over accidents, which can result in severe injury or death. All slopes require extra caution. If you cannot back up the slope or if you feel uneasy on it, do not mow it.

- Mow up and down slopes, not across.
- Watch for holes, ruts, bumps, rocks or other hidden obstacles. Uneven terrain could overturn the machine. Tall grass can hide obstacles.
- Choose a low ground speed so you will not have to stop or shift while on a slope.
- Do not mow on wet grass. Tires may lose traction.
- Always keep the machine in gear when going down slopes. Do not shift to neutral and coast downhill.
- Avoid starting, stopping or turning on a slope. If tires lose traction, disengage the blades and proceed slowly straight down the slope.
- Keep all movement on slopes slow and gradual. Do not make sudden changes in speed or direction, which could cause the machine to roll over.
- Use extra care while operating mower with grass catchers or other attachments; they can affect the stability of the machine. Do not use on steep slopes.
- Do not try to stabilize the machine by putting your foot on the ground.

- Do not mow near drop-offs, ditches, or embankments. The machine could suddenly turn over if a wheel goes over the edge of a cliff or ditch, or if an edge caves in.

## Children

Tragic accidents can occur if the operator is not alert to the presence of children. Children are often attracted to the machine and the mowing activity. Never assume that children will remain where you last saw them.

- Keep children out of the mowing area and under the watchful care of a responsible adult, not the operator.
- Be alert and turn the machine off if children enter the area.
- Before and while backing or changing direction, look behind, down, and side-to-side for small children.
- Never carry children, even with the blades off. They may fall off and be seriously injured or interfere with safe machine operation.
- Children who have been given rides in the past may suddenly appear in the mowing area for another ride and be run over or backed over by the mower.
- Never allow children to operate the machine.
- Use extra care when approaching blind corners, shrubs, trees, or other objects that may block your view of a child.

## Towing

- Tow only with a machine that has a hitch designed for towing. Do not attached towed equipment except at the hitch point.
- This product has a limited towing capacity for small attachments, such as leaf sweepers, rollers or carts. The combined weight of the attachment and load should not exceed the weight of the tractor. Use of these types of attachments should be limited to flat ground.
- Never allow children or others in or on towed equipment.
- On slopes, the weight of towed equipment may cause a loss of traction and control.
- Travel slowly and allow extra distance to stop.

## Service

To avoid personal injury or property damage, use extreme care in handling gasoline. Gasoline is extremely flammable and the vapors are explosive.

- Extinguish all cigarettes, cigars, pipes and other sources of ignition.

- Use only an approved gasoline container.
- Never remove the gas cap or add fuel when the engine is running. Allow the engine to cool before refueling.
- Never refuel the machine indoors.
- Never store the machine or fuel container where there is an open flame, spark, or pilot light such as a water heater or other appliances.
- Never fill containers inside a vehicle or on a truck or trailer with a plastic liner. Always place containers on the ground away from your vehicle before filling.
- Remove gas-powered equipment from the truck or trailer and refuel it on the ground. If this is not possible, then refuel such equipment with a portable container, rather than from a gasoline dispenser nozzle.
- Keep the nozzle in contact with the rim of the fuel tank or container opening at all times until the fueling is complete. Do not use a nozzle lock-open device.
- If fuel is spilled on clothing, change clothing immediately.
- Never overfill the fuel tank. Replace gas cap and tighten securely.
- Never run a machine inside a closed area.
- Keep nuts and bolts tight to be sure the equipment is in safe working condition.
- Never tamper with safety devices. Check their proper operation regularly.
- Keep the machine free of grass, leaves, or other debris build-up. Clean up oil or fuel spillage fuel soaked debris. Allow the machine to cool before storing.
- If you strike a foreign object, stop and inspect the mower. Repair, if necessary, before restarting.
- Never make any adjustments or repairs with the engine running.
- Check grass catcher components and the discharge guard frequently and replace with manufacturer's recommended parts, when necessary.
- Mower blades are sharp and can cut. Wrap the blade(s) or wear gloves, and use extra caution when servicing them.
- Check brake operation frequently. Adjust and service as required.
- Maintain or replace safety and instruction decals as necessary.

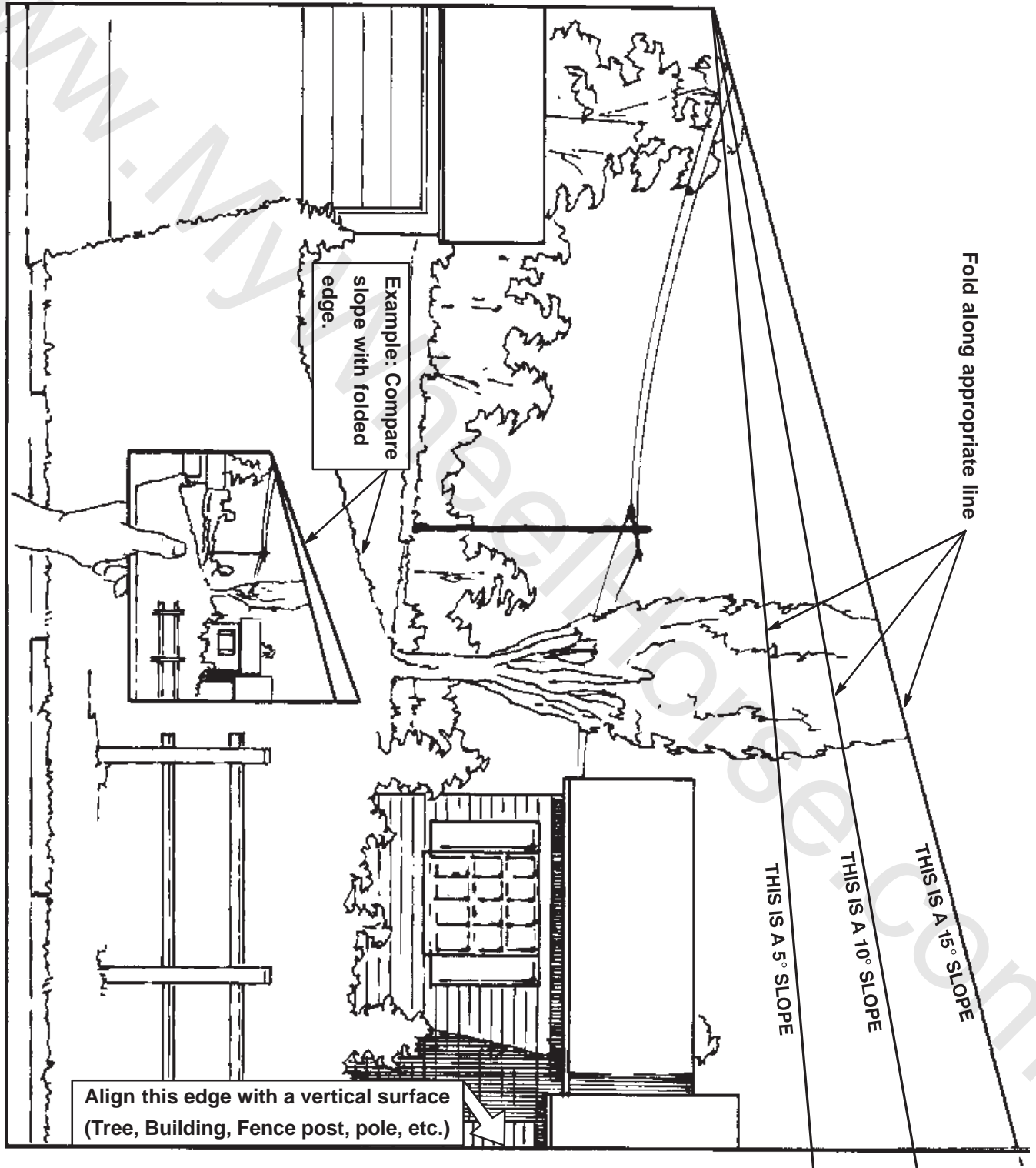
## Toro Riding Mower Safety

The following list contains safety information specific to Toro products or other safety information that you must know that is not included in the ANSI standards.

- Stop the engine, disconnect spark plug wire(s) and remove key before performing any service, repairs, maintenance or adjustments.
- Never leave a running machine unattended. Always turn off blades, set parking brake, stop engine, and remove the ignition and KeyChoice™ keys before dismounting.
- Keep hands, feet, hair and loose clothing away from attachment discharge area, underside of mower and any moving parts while engine is running.
- Do not touch equipment or attachment parts which may be hot from operation. Allow to cool before attempting to maintain, adjust or service.
- Battery acid is poisonous and can cause burns. Avoid contact with skin, eyes and clothing. Protect your face, eyes and clothing when working with a battery.
- Battery gases can explode. Keep cigarettes, sparks and flames away from battery.
- Use only Toro approved attachments. Warranty may be voided if used with unapproved attachments.
- Do not mow across slopes exceeding 5 degrees.
- Do not mow up slopes exceeding 10 degrees.
- Do not mow down slopes exceeding 15 degrees.
- If a steep slope must be ascended, back up the hill, and drive forward down the hill, keeping the machine in gear.
- Use only genuine Toro replacement parts to ensure that original standards are maintained.

[www.MyWheelHorse.com](http://www.MyWheelHorse.com)

# Slope Chart



[www.MyWheelHorse.com](http://www.MyWheelHorse.com)



# Safety and Instruction Decals



Safety decals and instructions are easily visible to the operator and are located near any area of potential danger. Replace any decal that is damaged or lost.

**⚠ DANGER**

**TO AVOID SERIOUS INJURY OR DEATH:**

- READ AND UNDERSTAND THE OPERATOR'S MANUAL.
- KNOW LOCATION AND FUNCTION OF CONTROLS.
- NEVER USE WHEN UNDER THE INFLUENCE OF ALCOHOL OR DRUGS.
- USE SAFELY; MACHINE IS NOT A TOY; NEVER LET CHILDREN OPERATE.
- GO UP AND DOWN SLOPES, NOT ACROSS.
- AVOID SHARP OR SUDDEN TURNS AND SLIPPERY OR STEEP AREAS.
- IF MACHINE STOPS GOING UPHILL, STOP BLADE AND BACK SLOWLY DOWN.
- NEVER MOW WHEN CHILDREN OR OTHERS ARE IN THE MOWING AREA.
- NEVER CARRY CHILDREN OR OTHER PASSENGERS.
- LOOK DOWN AND BEHIND BEFORE AND WHILE BACKING UP.
- KEEP SAFETY DEVICES IN PLACE AND WORKING; CHECK BEFORE EACH USE.
- SAFETY INTERLOCKS CAN FAIL; NEVER ASSUME BLADE IS STOPPED.
- STOP ENGINE, SET PARKING BRAKE AND REMOVE KEY IF LEAVING MACHINE.
- REMOVE OBJECTS THAT COULD BE THROWN BY THE BLADE.

NEVER MOW DOWNHILL OR UPHILL

98-0750

98-0750

**PARKING BRAKE**

**TO ENGAGE:  
DEPRESS BRAKE  
PEDAL AND PULL  
LEVER.**

**TO DISENGAGE:  
DEPRESS BRAKE  
PEDAL.**

111510

111510

**⚠ DANGER**

**• ROTATING BLADES CAN CUT OFF ARMS AND LEGS.**

**• NEVER MOW WHEN CHILDREN ARE NEAR.**

**• NEVER CARRY RIDERS; THEY FALL OFF.**

92-8946

92-8946

**KEY CHOICE**  
reverse mowing

99-5339

99-5339

**RANGE SELECTOR**

← LOW HIGH →

**GEAR SHIFT**

3 2  
N  
R 1

111534

111534

**NO. 1**

**See important warning information on side label!**

**Voir information d'avertissement importante sur l'étiquette de côté!**

**¡Aviso importante favor de observar las instrucciones en la etiqueta lateral!**

3-4479

104-4163

**DO NOT OPERATE WITH BATTERY DISCONNECTED. DAMAGE TO ELECTRICAL SYSTEM WILL RESULT.**

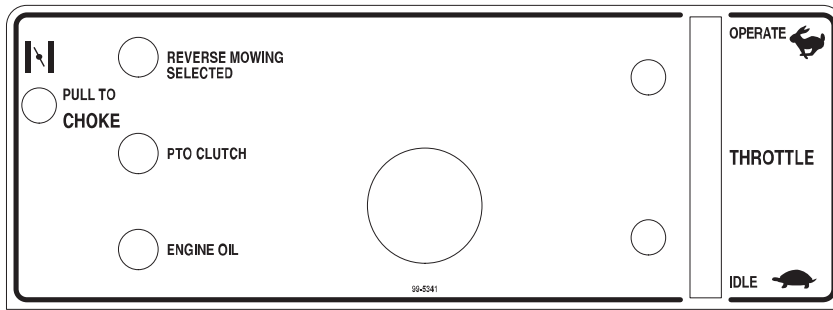
111926

**⚠ DANGER**

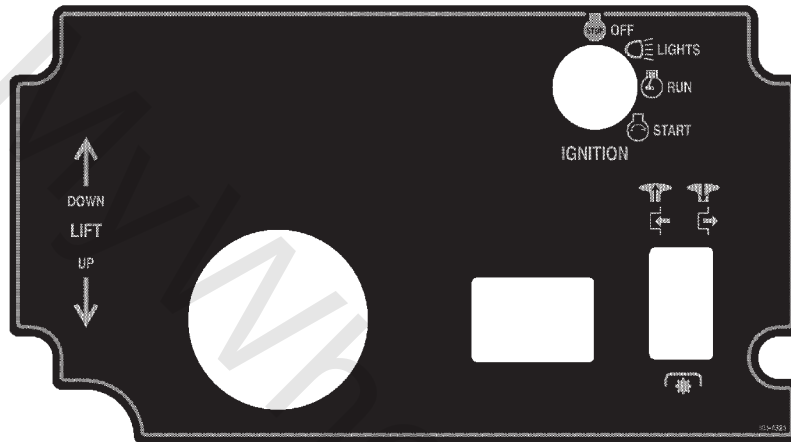
**NEVER MOW IN REVERSE IF THERE IS ANY POSSIBILITY OF CHILDREN APPEARING IN THE MOWING AREA.**

99-2985

99-2985

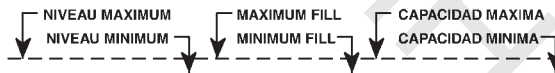


99-5341



104-4324

MAINTENANCE FREE • SANS ENTRETIEN • LIBRE DE MANTENIMIENTO



**⚠ DANGER/POISON ¡PELIGRO/VENENO!**

<p><b>SHIELD EYES.</b> EXPLOSIVE GASES CAN CAUSE BLINDNESS OR INJURY.</p> <p><b>PROTÉGER LES YEUX.</b> GAZ EXPLOSIFS PEUVENT RENDRE AVEUGLE OU PROVOQUER DES LÉSIONS.</p> <p><b>PROTEJA LOS OJOS.</b> GASES EXPLOSIVOS PUEDEN CAUSAR CEGUERA O DAÑO.</p>	<p><b>NO SPARKS • FLAMES • SMOKING</b></p> <p><b>ÉLOIGNER</b> • ÉTINCELLES • FLAMMES • CIGARETTES</p> <p><b>NO CHISPAS • FLAMAS • FUMAR</b></p>	<p><b>SULFURIC ACID</b> CAN CAUSE BLINDNESS OR SEVERE BURNS.</p> <p><b>ACIDE</b> SULFURIQUE PEUT RENDRE AVEUGLE OU PROVOQUER DES BRULURES GRAVES.</p> <p><b>ACIDO</b> SULFURICO PUEDE CAUSAR CEGUERA O QUEMADURAS SEVERAS.</p>	<p><b>FLUSH EYES IMMEDIATELY WITH WATER. GET MEDICAL HELP FAST.</b></p> <p><b>RINCER IMMEDIATEMENT LES YEUX A GRANDE EAU. CONTACTER RAPIDEMENT UN MEMBRE DE LA PROFESSION MEDICALE.</b></p> <p><b>LAVE LOS OJOS DE INMEDIATO. CONSIGA AYUDA MEDICA RAPIDO.</b></p>
--	---	--	--

**KEEP OUT OF THE REACH OF CHILDREN. DO NOT TIP. DO NOT OPEN BATTERY!**  
**MAINTENIR HORS DE LA PORTÉE DES ENFANTS. NE RENVERSEZ PAS. N'OUVREZ PAS LA BATTERIE!**  
**MANTENGASE FUERA DEL ALCANCE DE LOS NIÑOS. NO INCLINE. NO ABRA LA BATERIA!**

**HOW TO ACTIVATE DRY CHARGED BATTERIES**

1. Use only battery electrolyte (1.265 Sp. Gr.) to fill battery initially.
2. Do not overfill. Let stand for 15 minutes.
3. Charge battery at 4-5 amps until specific gravity is 1.250 or higher and temperature is at least 60°F. - all cells gassing freely.
4. After battery has been activated, add only water to replace normal loss.



34915 Dist. by: /por:/par: EPM Products, Baltimore, MD 21226 MADE IN U.S.A. • FABRIQUE AUX E.U.A. • HECHO EN E.U.A.



104-5091

# Gasoline and Oil

## Recommended Gasoline

Use UNLEADED Regular Gasoline suitable for automotive use (85 pump octane minimum). Leaded regular gasoline may be used if unleaded regular is not available.

**Important** Never use methanol, gasoline containing methanol, or gasohol containing more than 10% ethanol because the fuel system could be damaged. Do not mix oil with gasoline.

 **Danger** 

**In certain conditions, gasoline is extremely flammable and highly explosive. A fire or explosion from gasoline can burn you and others and can damage property.**

- Fill the fuel tank outdoors, in an open area, when the engine is cold. Wipe up any gasoline that spills.
- Do not fill the fuel tank completely full. Add gasoline to the fuel tank until the level is 1/4 in. to 1/2 in. (6 mm to 13 mm) below the bottom of the filler neck. This empty space in the tank allows gasoline to expand.
- Never smoke when handling gasoline, and stay away from an open flame or where gasoline fumes may be ignited by a spark.
- Store gasoline in an approved container and keep it out of the reach of children. Never buy more than a 30-day supply of gasoline.
- Always place gasoline containers on the ground away from your vehicle before filling.
- Do not fill gasoline containers inside a vehicle or on a truck or trailer bed because interior carpets or plastic truck bed liners may insulate the container and slow the loss of any static charge.
- When practical, remove gas-powered equipment from the truck or trailer and refuel the equipment with its wheels on the ground.
- If this is not possible, then refuel such equipment on a truck or trailer from a portable container, rather than from a gasoline dispenser nozzle.
- If a gasoline dispenser nozzle must be used, keep the nozzle in contact with the rim of the fuel tank or container opening at all times until fueling is complete.

## Using Stabilizer/Conditioner

Use a fuel stabilizer/conditioner in the machine to provide the following benefits:

- Keeps gasoline fresh during storage of 90 days or less. For longer storage it is recommended that the fuel tank be drained.
- Cleans the engine while it runs
- Eliminates gum-like varnish buildup in the fuel system, which causes hard starting

**Important** Do not use fuel additives containing methanol or ethanol.

Add the correct amount of gas stabilizer/conditioner to the gas.

**Note:** A fuel stabilizer/conditioner is most effective when mixed with fresh gasoline. To minimize the chance of varnish deposits in the fuel system, use fuel stabilizer at all times.

## Filling the Fuel Tank

1. Shut the engine off and set the parking brake.
2. Clean around fuel tank cap and remove the cap. Add unleaded regular gasoline to both fuel tank, until the level is 1/4 to 1/2 inch (6 mm to 13 mm) below the bottom of the filler neck. This space in the tank allows gasoline to expand. Do not fill the fuel tanks completely full.
3. Install fuel tank cap securely. Wipe up any gasoline that may have spilled.

## Checking the Engine Oil Level

Before you start the engine and use the machine, check the oil level in the engine crankcase; refer to Checking Oil Level, page 24.

# Setup

**Note:** Determine the left and right sides of the machine from the normal operating position.

## Loose Parts

**Note:** Use the chart below to identify parts for assembly.



DESCRIPTION	QTY.	USE
Hitch Pin	1	Installing the hitch pin
Hairpin Cotter – 1-7/8 in.	1	
Flat Washer – 1/2 x 1 in.	1	
Bolt – 1/4 x 3/4 in.	2	Attaching the battery cables
Hex Nut – 1/4 in.	2	
Hairpin Cotter – 1-7/8 in.	1	Attaching accessory to lift bar
Flat Washer – 1/2 x 1 in.	1	
Operator's Manual	1	Read before operating tractor
Set Up Instructions	1	Read before setting up tractor
Riding Mower Safety Video	1	View before operating tractor

## Checking the Tire Pressure

Check the front and rear tire pressure. The correct front and rear tire pressure is 12 psi (83 kPa).

## Activating the Battery

Bulk electrolyte with 1.265 specific gravity must be purchased from a local battery supply outlet.

 **Danger** 

**Battery electrolyte contains sulfuric acid which is a deadly poison and causes severe burns.**

- **Do not drink electrolyte and avoid contact with skin, eyes or clothing. Wear safety glasses to shield your eyes and rubber gloves to protect your hands.**
- **Fill the battery where clean water is always available for flushing the skin.**
- **Follow all instructions and comply with all safety messages on the electrolyte container.**

1. Remove the battery from the tractor.
2. Clean the top of the battery with a paper towel.

**Note:** Never fill the battery with electrolyte while the battery installed in the tractor. Electrolyte could be spilled on other parts and cause corrosion.

3. Remove the vent caps from the battery (Fig. 2).

- Slowly pour electrolyte into each battery cell until the level is up to the upper line on the battery case (Fig. 2).

**Important** Do not overfill the battery because electrolyte (sulfuric acid) can cause severe corrosion and damage to the chassis.

- Wait five to ten minutes after filling the battery cells. Add electrolyte, if necessary, until the electrolyte level is up to the upper line on the battery case (Fig. 2).
- Reinstall battery filler caps.

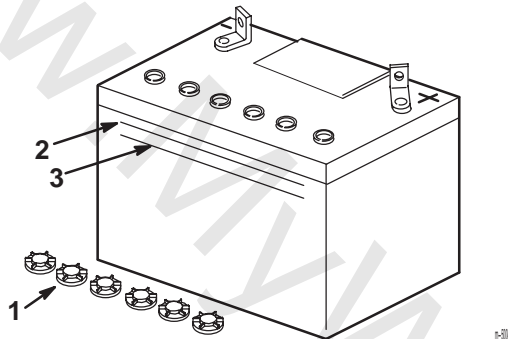


Figure 2

- Filler caps
- Upper line
- Lower line

**Warning**

**Charging the battery produces gasses that can explode.**

**Never smoke near the battery and keep sparks and flames away from battery.**

- Make sure the vent caps are installed in battery. Charge battery for 10 to 15 minutes at 25 to 30 amps or 30 minutes at 4–6 amps.
- When the battery is fully charged, unplug the charger from the electrical outlet, then disconnect the charger leads from the battery posts (Fig. 3).

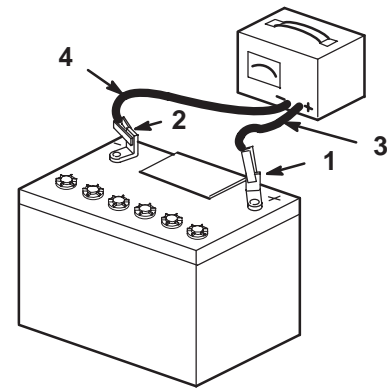


Figure 3

- Positive Battery Post
- Negative Battery Post
- Red (+) Charger Lead
- Black (-) Charger Lead

- Install the battery in the tractor and connect the battery cables. Refer to the Installing the Battery on page 31.

**Note:** Do not run the tractor with the battery disconnected, electrical damage may occur.

## Installing the Drawbar Hitch Pin

Insert the drawbar hitch pin into the drawbar hitch and secure it with a flat washer (1/2 x 1 in.) and one hairpin cotter (1-7/8 in.) (Fig. 4).

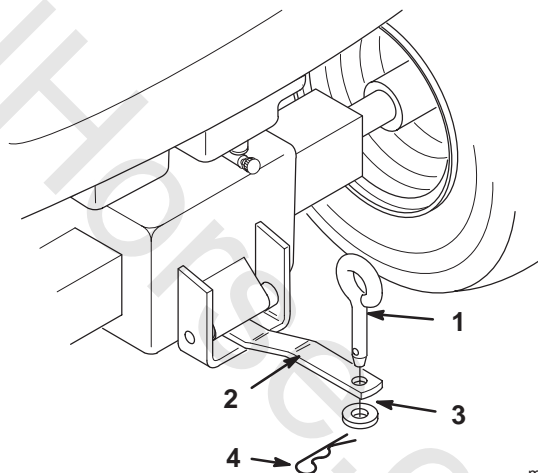
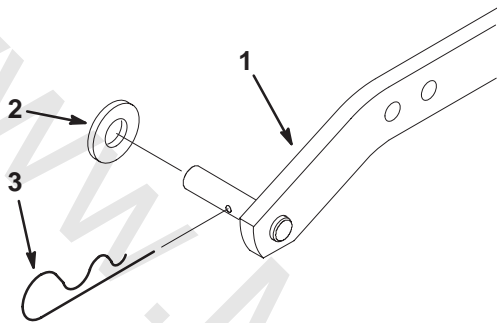


Figure 4

- Drawbar Hitch Pin
- Drawbar Hitch
- Flat Washer, 1/2 x 1 in.
- Hairpin Cotter, 1-7/8 in.

## Attaching the Washer and Hairpin Cotter onto the Lift Bar

Install a flat washer (1/2 x 1 in.) and a hairpin cotter (1-7/8 in.) onto the lift bar (Fig 5).



m-2504

Figure 5

1. Lift Bar
2. Flat Washer, 1/2 x 1 in.
3. Hairpin Cotter, 1-7/8 in.

## Checking the Wiring and Fasteners

- Inspect the tractor for any loose electrical connections and secure as required. Check the wire routing to make sure no moving parts interfere with the wires to cause a short.
- Check all fasteners to make sure they are tight.

## Checking the Engine Oil

**Important** The tractor is shipped from the factory with oil in the engine crankcase

Check the oil level and add only enough oil to raise the level to the full mark on the dipstick. Refer to Checking the Engine Oil on page 24.

## Learn to Operate the Tractor

Learn how to operate the tractor. Read the Operation section starting on page 15.

## Checking the Tractor Lubrication

Check the tractor to ensure it is lubricated. Refer to Greasing and Lubrication on page 26.

1. Check the oil level in the transaxle. Refer to Servicing the Transaxle for oil type, viscosity and capacity on page 29.

2. Check to make sure all lubrication points have been greased. These points include the front axle pivot and spindles, foot pedal(s) and steering gear.

## Test Driving the Tractor

1. Fill the tank with unleaded regular gasoline with an octane rating of at least 85. Open the fuel shutoff valve and check the fuel hose and fittings for leaks.
2. As applicable, check and test the operation of the following:
  - Engine, choke and throttle controls
  - Gauges
  - Headlights
  - Indicator lights
  - PTO clutch and brake
  - Lift system
  - Service and parking brakes
  - Transmission controls
  - Steering
  - Tractor operation in forward and reverse

## Checking the Safety System

Caution	
If safety interlock switches are disconnected or damaged the machine could operate unexpectedly causing personal injury.	
<ul style="list-style-type: none"><li>• Do not tamper with the interlock switches.</li><li>• Check the operation of the interlock switches daily and replace any damaged switches before operating the machine.</li></ul>	

Refer to Checking the Safety Interlock System on page 17.

# Operation

**Note:** Determine the left and right sides of the machine from the normal operating position.

## Think Safety First

Please carefully read all the safety instructions and symbols in the safety section. Knowing this information could help you, your family, pets or bystanders avoid injury.

## Controls

Become familiar with all the controls (Fig. 6) before you start the engine and operate the machine.

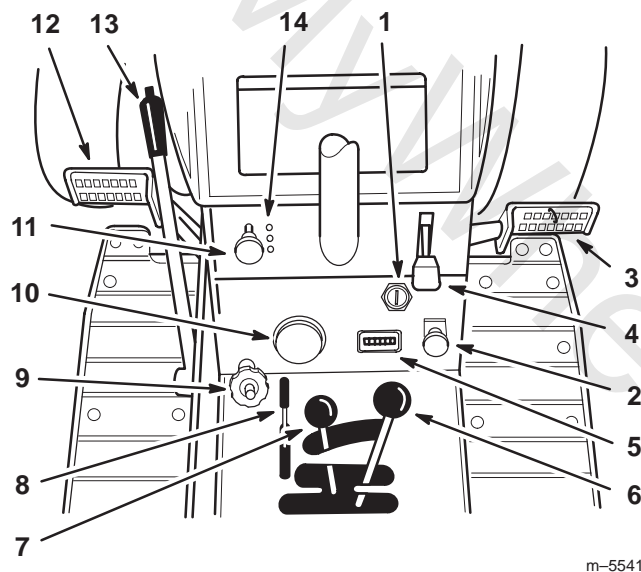


Figure 6

- |                         |                           |
|-------------------------|---------------------------|
| 1. Ignition/lightswitch | 8. Parking brake lever    |
| 2. Power take off (PTO) | 9. Dial-A-Height knob     |
| 3. Brake pedal          | 10. Voltmeter             |
| 4. Throttle lever       | 11. Choke lever           |
| 5. Hour meter           | 12. Clutch pedal          |
| 6. Gear shift           | 13. Attachment lift lever |
| 7. Range selector       | 14. Indicator lights      |

## Using the Parking Brake

Always set the parking brake when you stop the machine or leave it unattended.

## Setting the Parking Brake

1. Push the brake pedal (Fig. 7) down and hold it in the depressed position.
2. Move the parking brake lever (Fig. 7) back and gradually take your foot off the brake pedal. The brake pedal should stay in the depressed (locked) position.

## Releasing the Parking Brake

1. Push down on the brake pedal (Fig. 7). The parking brake lever should release.
2. Gradually release the brake pedal.

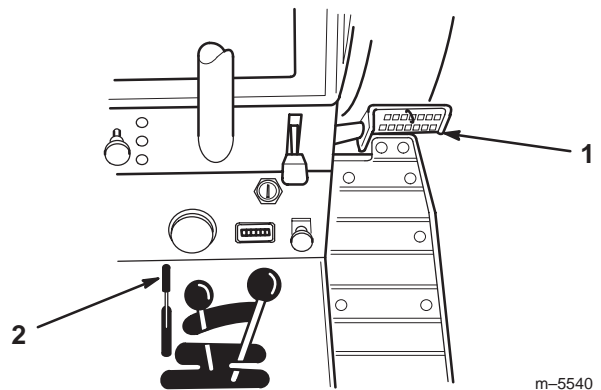


Figure 7

1. Brake pedal
2. Parking brake lever

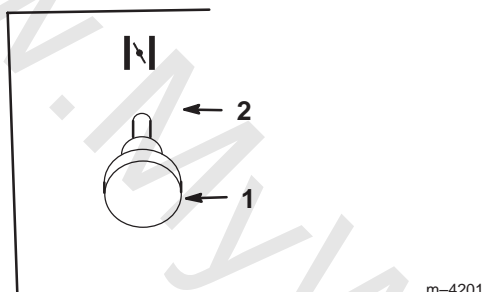
## Starting and Stopping the Engine

### Starting the Engine

1. Sit down on the seat.
2. Set the parking brake; refer to Setting the Parking Brake, page 15.
3. Move the PTO (power take off) to disengage (Fig. 11).
4. Move the gear shift lever to neutral; refer to Selecting Ground Speeds, page 19.
5. Move the choke to on (Fig. 8).
6. Move throttle lever midway between the slow and fast throttle positions (Fig. 9).
7. Depress the clutch.
8. Turn the ignition key clockwise and hold it in the start position (Fig. 10). When the engine starts, release the key.

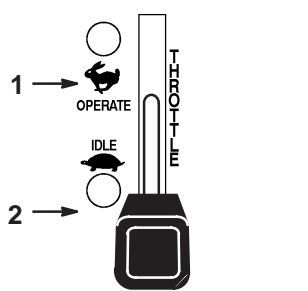
**Important** If the engine does not start after 10 seconds of continuous cranking, turn the ignition key to off and let the starter motor cool for 60 seconds; refer to Troubleshooting, page 36.

9. After a cold engine starts, move the choke to off gradually (Fig. 8). If the engine stalls or hesitates, move the choke lever back to on for a few seconds.
10. After a warm engine starts, move the choke to off immediately (Fig. 8).
11. Then move the throttle lever to desired setting. Repeat this as required.



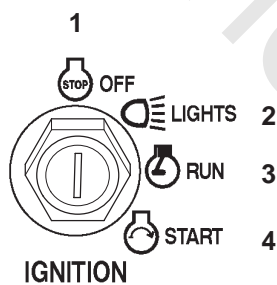
**Figure 8**

1. Choke—Off
2. Choke—On



**Figure 9**

1. Fast
2. Slow



**Figure 10**

1. Off
2. Lights
3. Run
4. Start

## Stopping the Engine

1. Push the PTO (power take off) to off (Fig. 11).
2. Move the throttle lever to slow (Fig. 9).
3. Let engine idle for 30–60 seconds.
4. Turn the ignition key to off (Fig. 10).

**Note:** If the engine has been working hard or is hot, let it idle for a minute before turning the ignition key off. This helps cool the engine before it is stopped. In an emergency, the engine may be stopped by turning the ignition key to off.

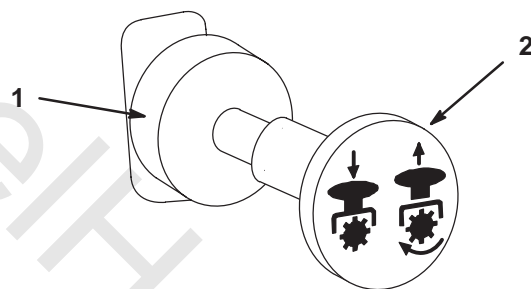
## Operating the Power Take Off (PTO)

The power take off (PTO) engages and disengages power to the electric clutch.

The PTO light, in the Indicator Module, will be on when the ignition key is in run or lights position and the power take off (PTO) is engaged. When this light is on it is a reminder the starter will not crank and to turn the off PTO before getting off the tractor.

### Engaging the Power Take Off (PTO)

1. Depress the clutch and brake pedals to stop the machine.
2. Pull the power take off (PTO) to on (Fig. 11).



**Figure 11**

1. PTO—Off
2. PTO—On

### Disengaging the Power Take Off (PTO)

1. Depress the clutch and brake pedals to stop the machine.
2. Push the power take off (PTO) to off (Fig. 11).

## Instruments

The gauges show conditions that need to be monitored during tractor operation. Read them to check operation immediately after starting the engine and regularly during use.



## Hour Meter

The hour meter records the number of hours the engine has operated (Fig. 12). It is turned on when the ignition switch is in the run position. Use these times for scheduling regular maintenance.

## Voltmeter

The voltmeter shows the electrical system battery voltage (Fig. 12). When you turn the ignition key to run, the gauge should read 12 volts or slightly higher. After the engine starts, the gauge should read between 12 and 15 volts. If the gauge reads less than 12 volts, the battery is discharging. If the gauge reads 15 volts for long periods of time, check the battery water more often.

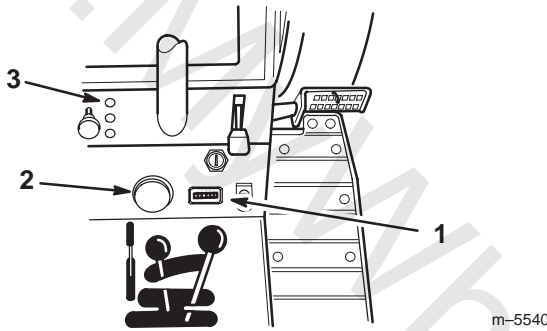


Figure 12

1. Hour meter
2. Voltmeter
3. Indicator lights

## Indicator Lights

The indicator lights (Fig. 13) illuminate when certain controls are activated and when certain conditions occur that need immediate attention. Under normal operating conditions the lights should be off.

- 1 REVERSE MOWING SELECTED
- 2 PTO CLUTCH
- 3 ENGINE OIL

Figure 13

1. Reverse mowing selected
2. PTO (power take off)
3. Engine Oil

## Operating-in-Reverse

The reverse mowing selected light (Fig. 13) will illuminate whenever the Keychoice switch is used to deactivate the operating-in-reverse interlock. It is a reminder that the interlock system is deactivated. The light goes out whenever the power take off (PTO) is disengaged or the engine is shut off.

## PTO (Power Take Off) Clutch

When the PTO clutch light is on it indicates the PTO clutch must be disengaged before the engine will start (Fig. 9).

## Engine Oil

When the oil light blinks it indicates the engine oil pressure is low (Fig. 9). After the engine starts the light should go out. When the engine is running if the oil pressure drops below a safe operating level the light blinks. **Stop engine immediately and correct the cause of low oil pressure.**

## Checking the Safety Interlock System

**Caution**

**If safety interlock switches are disconnected or damaged the machine could operate unexpectedly causing personal injury.**

- **Do not tamper with the interlock switches.**
- **Check the operation of the interlock switches daily and replace any damaged switches before operating the machine.**

## Understanding the Safety Interlock System

The safety interlock system is designed to prevent the engine from starting unless:

- You are sitting on the seat.
- The gear shift lever is in neutral.
- The power take off (PTO) is disengaged.

The safety interlock system is designed to stop the engine if:

- You rise from the seat when the power take off (PTO) is engaged.
- You rise from the seat when the gear shift lever is not in neutral.

- The parking brake is engaged and the gear shift lever is not in neutral.

The safety interlock system is designed to turn off the power take off (PTO) if:

- You shift into reverse with the power take off (PTO) engaged and the operating-in-reverse interlock is not deactivated.

## Testing the Safety Interlock System

Test the safety interlock system before you use the machine each time. If the safety system does not operate as described below, have an Authorized Service Dealer repair the safety system immediately.

1. While sitting on the seat, set the parking brake, move the gear shift lever to neutral and move the power take off (PTO) to disengaged. Now rise slightly from the seat and turn the ignition key to start; **the engine should not crank.**
2. While sitting on the seat, move the gear shift lever to neutral and move the power take off (PTO) to engaged. Now turn the ignition key to start; the engine should not crank.
3. While sitting on the seat, move the power take off (PTO) to disengaged and move the gear shift lever out of neutral. Now turn the ignition key to start; the engine should not crank.
4. While sitting on the seat, set the parking brake, move the gear shift lever to neutral and move the power take off (PTO) to disengaged. Now start the engine. While the engine is running, move the power take off (PTO) to engaged and rise slightly from the seat; the engine should stop.
5. While sitting on the seat, set the parking brake, move the gear shift lever to neutral and move the power take off (PTO) to disengaged. Now start the engine. While the engine is running, release the parking brake, depress the clutch, place the gear shift lever into gear, and begin driving the tractor. While driving rise slightly from the seat; the engine should stop.
6. While sitting on the seat, set the parking brake, move the gear shift lever to neutral and move the power take off (PTO) to disengaged. Now start the engine. While the engine is running, depress the clutch and place the gear shift lever into gear; the engine should stop.
7. While sitting on the seat, move the PTO in the disengage position and the gear shifter in neutral. Now start the engine. While the engine is running, move the

PTO to the engage position, push in the clutch and put the gear shifter in reverse. The PTO clutch should disengage.

8. While sitting on the seat, move the PTO in the disengage position and the gear shifter in neutral. Now start the engine. Move the PTO to the engage position and turn the KeyChoice key and release. The Operating-in-Reverse warning light should illuminate. Move the PTO to the disengage position and the Operating-in-Reverse warning light should turn off.

## Setting the KeyChoice<sup>®</sup> Switch to Operate in Reverse

An interlock feature on the tractor prevents the power take off (PTO) from operating when backing up. If you shift into reverse with the PTO engaged (i.e., with mower blades or other attachment running), the PTO clutch will disengage. **Do not mow in reverse unless absolutely necessary.**

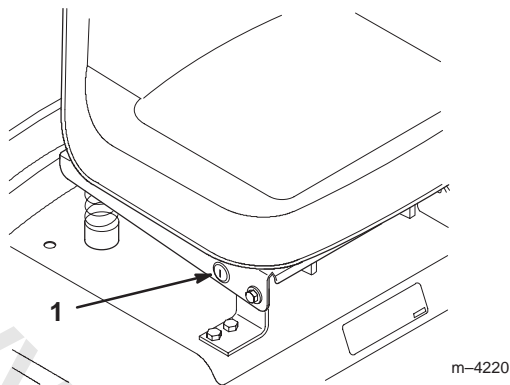
If you need to use the PTO while backing up, you can turn off this interlock feature using the KeyChoice switch located near the seat bracket (Fig. 14).

!
Danger
!

**You could back over a child or bystander while the mower blade(s) or other attachment is engaged and cause serious injury or death.**

- **Do not mow in reverse unless absolutely necessary.**
- **Do not insert the KeyChoice key unless it is absolutely necessary.**
- **Always look backward and down before backing up.**
- **Use the KeyChoice switch only if you are certain no children or other bystanders will enter the mowing area.**
- **Be very observant after deactivating the interlock because the sound of the engine may prevent you from noticing that a child or bystander has entered the work area.**
- **Always remove both the ignition and KeyChoice keys and put them in a safe place out of the reach of children or unauthorized users when leaving the unit unattended.**

1. Engage the PTO.
2. Insert the KeyChoice key into the switch (Fig. 14).

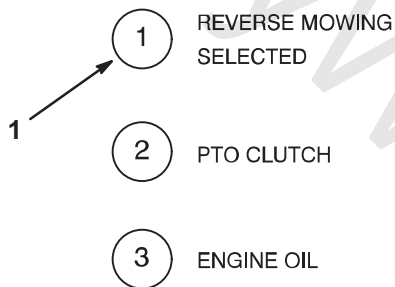


**Figure 14**

1. KeyChoice switch

3. Turn the KeyChoice key.

A red light on the front console (Fig. 15) turns on, indicating that the interlock is disabled.



**Figure 15**

1. Operating-in-reverselight

4. Shift into reverse and complete your task.
5. Stop the PTO of the engine to activate the interlock.
6. Remove the KeyChoice key and put it in a safe place out of reach of children.

## Driving Forward or Backward

The throttle control regulates the engine speed as measured in rpm (revolutions per minute). Place the throttle control in the fast position for best performance.

**Caution**

**If you release the clutch pedal too quickly when the ground speed selector is in gear, you could suddenly put the machine in motion.**

- Always release the clutch pedal slowly when starting the machine in motion (forward or reverse).

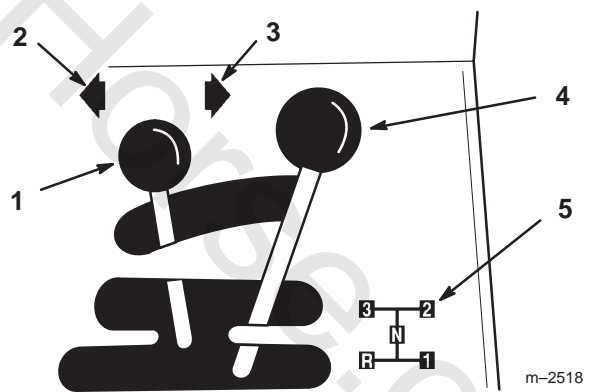
To go forward or backward, depress the clutch and brake pedals. Move the range selector to the desired high–low location and select a forward or reverse gear. Release the brake pedal. As you slowly release the clutch pedal, the machine will begin to move. Steer the machine with the steering wheel.

**Note:** For reverse motion, with the PTO engaged, the operating–in–reverse interlock must be deactivated by the Keychoice switch located on the seat bracket on the right hand side just below the seat.

## Selecting the Ground Speeds

**Important** To avoid transmission damage, always depress the clutch and brake pedals before shifting gears or high–low range.

Always start the machine and change gears by depressing the clutch pedal (Fig. 16). In most conditions, the machine is powerful enough to move out in any speed. If it will not move out in a selected speed (i.e., #5) due to a heavy load, use a lower speed (i.e., #2).



**Figure 16**

1. Range selector
2. Low range
3. High range
4. Ground speeds selector
5. Gear location 1-3, R

## Stopping the Machine

To stop the machine, depress the clutch and brake pedals, disengage the power take off (PTO), and turn the ignition key to off. Also set the parking brake if you leave the machine unattended; refer to Setting the Parking Brake, page 15. Remember to remove the ignition and Keychoice keys.

**Caution**

**Children or bystanders may be injured if they move or attempt to operate the tractor while it is unattended.**

**Always remove the ignition and KeyChoice keys and set the parking brake when leaving the machine unattended, even if just for a few minutes.**

**Important** To prevent excessive wear, do not ride the brakes. Shift to a lower gear for slower ground speed. Choose a slow speed so that you will not have to stop or shift while on a slope.

## Using the Attachment Lift Lever

The attachment lift lever is used to raise and lower various attachments (Fig. 17).

### Raising Attachments

1. Depress the clutch and brake pedals to stop the machine.
2. Pull attachment lift lever rearward until latch locks. In this position the lift will hold the attachment in the up, or raised position.

### Lowering Attachments

1. Depress the clutch and brake pedals to stop the machine.
2. Pull attachment lift lever rearward, to release lift pressure, and push the button on top to release the latch. Move lift lever forward to lower attachment.

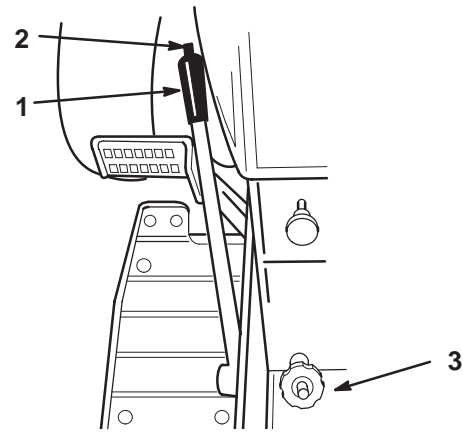


Figure 17

1. Lift lever
2. Button
3. Dial-A-Height

## Adjusting the Dial-A-Height

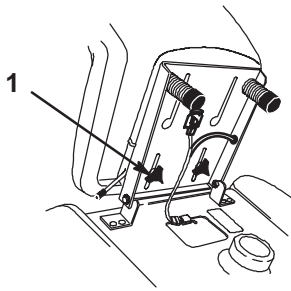
The Dial-A-Height control is used to limit the downward travel of attachments other than mowers (Fig. 17). For example, use the Dial-a-Height to hold the blade or snowthrower above a gravel drive to prevent picking up stones or hold the tiller at a selected depth. For mowing, turn the Dial-a-Height fully counterclockwise until the knob contacts the plastic thread cap, so the mower can move through its full range of travel. Use the mower's height control to set cutting height. To use the Dial-a-height:

1. Raise the attachment lift lever; refer to Raising Attachments. In the raised position the Dial-A-Height knob (Fig. 17) can be rotated to change the stop location. Turn right to raise and left to lower the height of the attachment.

## Positioning the Seat

The seat can move forward and backward. Position the seat where you have the best control of the machine and are most comfortable.

1. Raise the seat and loosen the adjustment knobs (Fig. 18).
2. Slide the seat to the desired position and tighten the knobs.

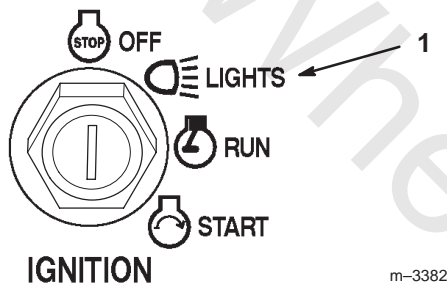


**Figure 18**

1. Adjustment knob

## Using the Lights

The headlights are turned on with a separate position, lights, of the ignition switch (Fig. 19). The lights are on while the ignition switch is in the lights position even with the engine off. Remove the key when the machine is left unattended so lights cannot be turned on discharging the battery.



**Figure 19**

1. Light position

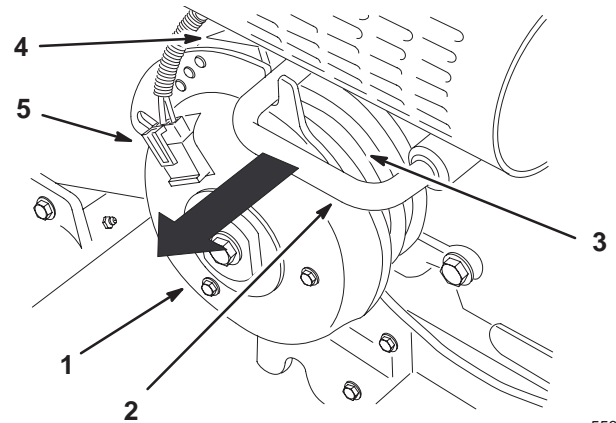
## Installing PTO Belt

1. Park the machine on a level surface, disengage the power take off (PTO), set the parking brake, stop the engine and remove the key.
2. Remove the belt cover.
3. Unplug the clutch connector (Fig. 20).
4. Pull out the PTO stop out of the clutch (Fig. 20).
5. Rotate the clutch to allow space between the belt guide and the clutch. This will allow the belt to be installed onto a clutch pulley (Fig. 20).
6. Place belt into a clutch pulley (Fig. 20).

**Note:** Install belt in the inside pulley groove for mowers and the outside pulley groove for a tiller or snowthrower.

7. Install the PTO stop back into the clutch (Fig. 20).
8. Install the clutch connector (Fig. 20).

9. Install the belt cover.



**Figure 20**

- |                |                     |
|----------------|---------------------|
| 1. PTO clutch  | 4. Belt guide       |
| 2. PTO stop    | 5. Clutch connector |
| 3. Belt groove |                     |

# Maintenance

## Recommended Maintenance Schedule

Maintenance Service Interval	Maintenance Procedure
After First Use	<ul style="list-style-type: none"> <li>• Change oil</li> </ul>
Each Use	<ul style="list-style-type: none"> <li>• Check oil level</li> <li>• Check safety system</li> <li>• Check brake</li> <li>• Clean outside of engine</li> <li>• Check transaxle fluid</li> </ul>
Every 5 Hours	<ul style="list-style-type: none"> <li>• Check battery electrolyte</li> </ul>
Every 25 Hours	<ul style="list-style-type: none"> <li>• Service foam air cleaner<sup>1</sup></li> <li>• Check tire pressure</li> </ul>
Every 50 Hours	<ul style="list-style-type: none"> <li>• Grease chassis<sup>1</sup></li> <li>• Check belts for wear/cracks</li> </ul>
Every 100 Hours	<ul style="list-style-type: none"> <li>• Change oil<sup>1</sup></li> <li>• Replace paper air cleaner<sup>1</sup></li> <li>• Replace fuel filter</li> <li>• Check front wheel toe-in</li> <li>• Clean outside of engine</li> <li>• Adjust PTO Clutch/Brake adjust</li> </ul>
Every 200 Hours	<ul style="list-style-type: none"> <li>• Change oil filter<sup>1</sup></li> <li>• Check spark plug(s)</li> </ul>
At storage	<ul style="list-style-type: none"> <li>• Chipped Surfaces—paint</li> <li>• Perform all maintenance procedures listed above before storage</li> </ul>
After Storage	<ul style="list-style-type: none"> <li>• Check safety system</li> <li>• Check brake</li> <li>• Check spark plug(s)</li> <li>• Check battery electrolyte</li> <li>• Check tire pressure</li> </ul>

<sup>1</sup>More often in dusty, dirty conditions

**Important** Refer to your engine operator's manual for additional maintenance procedures.

**Note:** Determine the left and right sides of the machine from the normal operating position.

Caution

**If you leave the key in the ignition switch, someone could accidentally start the engine and seriously injure you or other bystanders.**

**Remove the key from the ignition and disconnect the wire from the spark plug before you do any maintenance. Set the wire aside so that it does not accidentally contact the spark plug.**

# Servicing the Air Cleaner

## Service Interval/Specification

**Foam Element:** Clean and re-oil after every 25 operating hours, or yearly, whichever occurs first.

**Paper Element:** Replace after every 100 operating hours or yearly, whichever occurs first.

**Note:** Service the air cleaner more frequently (every few hours) if operating conditions are extremely dusty or sandy.

## Removing the Foam and Paper Elements

1. Disengage the power take off (PTO), set the parking brake, and turn the ignition key to off. Remove the ignition and Key choice keys.
2. Open the hood.
3. Clean around the air cleaner to prevent dirt from getting into the engine and causing damage. Remove the wing nut and air cleaner cover (Fig. 21).

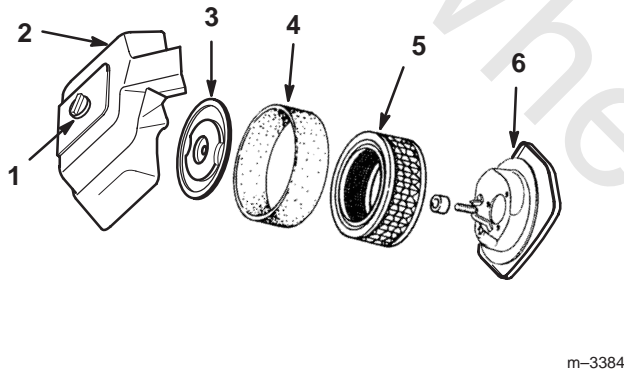


Figure 21

- |                      |                     |
|----------------------|---------------------|
| 1. Wing nut          | 4. Foam element     |
| 2. Air cleaner cover | 5. Paper element    |
| 3. Cover             | 6. Air cleaner base |

4. Unscrew the nut and remove the cover, foam element and paper element (Fig. 21).
5. Carefully slide the foam element off the paper element (Fig. 21).

## Cleaning the Foam Elements

1. Wash the foam element in liquid soap and warm water. When the element is clean, rinse it thoroughly.
2. Dry the element by squeezing it in a clean cloth.
3. Put one or two ounces of oil on the element (Fig. 22). Squeeze the element to distribute the oil.

**Important** Replace the foam element if it is torn or worn.

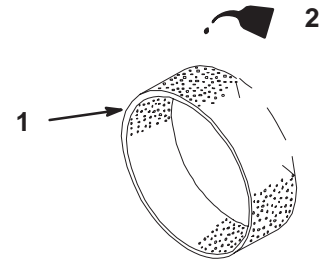


Figure 22

- |                 |        |
|-----------------|--------|
| 1. Foam element | 2. Oil |
|-----------------|--------|

## Cleaning the Paper Element

1. Lightly tap the element on a flat surface to remove dust and dirt (Fig. 23).
2. Inspect the element for tears, an oily film, and damage to the rubber seal.

**Important** Never clean the paper element with pressurized air or liquids, such as solvent, gas, or kerosene. Replace the paper element if it is damaged or cannot be cleaned thoroughly.

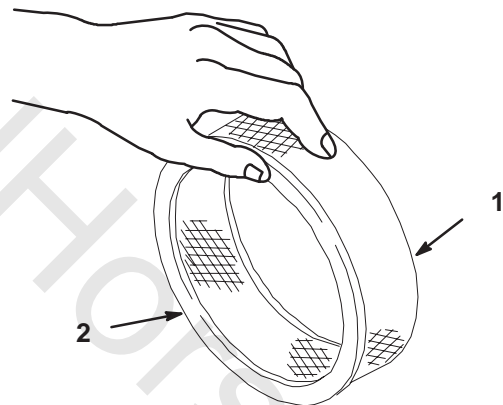


Figure 23

- |                  |                |
|------------------|----------------|
| 1. Paper element | 2. Rubber seal |
|------------------|----------------|

## Installing the Foam and Paper Elements

**Important** To prevent engine damage, always operate the engine with the complete foam and paper air cleaner assembly installed.

1. Carefully slide the foam element onto the paper air cleaner element (Fig. 21).
2. Place the air cleaner assembly into air cleaner base. Slide cover onto rod and secure with nut (Fig. 21).

3. Install the air cleaner cover and secure with wing nut (Fig. 21).
4. Close the hood.

## Servicing the Engine Oil

### Service Interval/Specification

Change oil:

- After the first 5 operating hours.
- After every 100 operating hours.

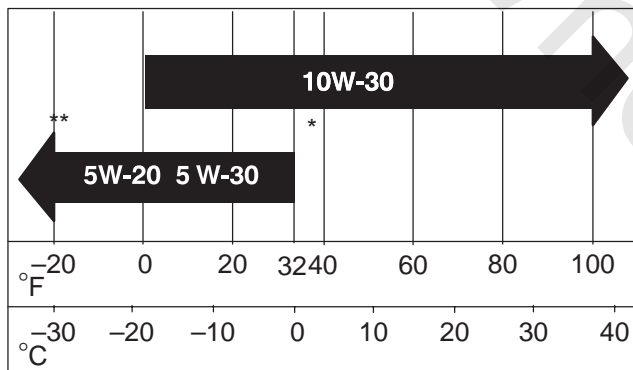
**Note:** Change oil more frequently when operating conditions are extremely dusty or sandy.

Oil Type: Detergent oil (API service SG or SH)

Crankcase Capacity: without filter, 3-1/2 pints (1.7 l)  
with filter, 4 pints (1.9 l)

Viscosity: See table below

#### USE THESE SAE VISCOSITY OILS



\*Use of synthetic oil having 5W-20 or 5W-30 rating is acceptable, up to 40° F).

\*\*Synthetic oils will provide better starting in extreme cold (below -10° F).

### Checking the Engine Oil Level

1. Park the machine on a level surface, disengage the power take off (PTO), set the parking brake, and turn the ignition key to off. Remove the key.

2. Open the hood.
3. Clean around the oil dipstick (Fig. 24) so dirt cannot fall into the filler hole and damage the engine.
4. Pull the oil dipstick out and wipe the metal end clean (Fig. 24).
5. Push the oil dipstick fully into the filler tube (Fig. 24). Pull the dipstick out and look at the metal end. If oil level is low, slowly pour only enough oil into the filler tube to raise the level to the full mark.

**Important** Do not overfill the crankcase with oil because the engine may be damaged.

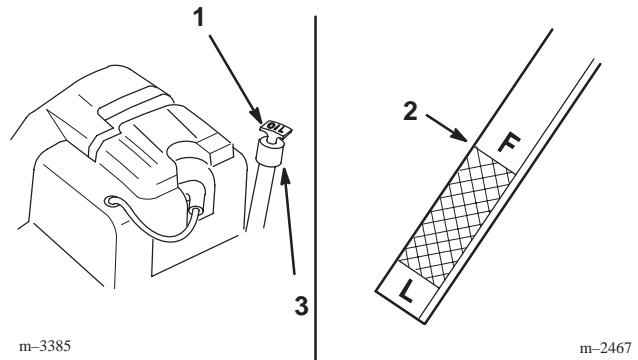


Figure 24

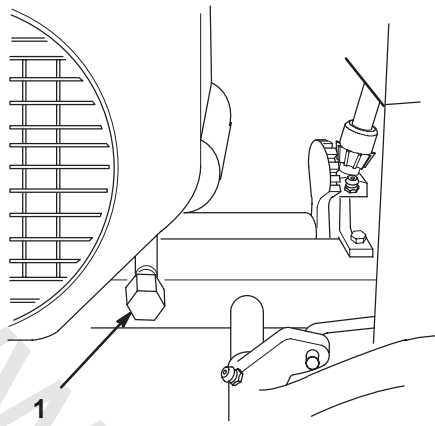
1. Oil dipstick
2. Metal end
3. Filler tube

### Changing the Oil

1. Start the engine and let it run five minutes. This warms the oil so it drains better.
2. Park the machine so that the drain side is slightly lower than the opposite side to assure the oil drains completely. Then disengage the power take off (PTO), set the parking brake, and turn the ignition key to off. Remove the key.
3. Open the hood.
4. Place a pan below the oil drain. Open the drain by removing the cap (Fig. 25).
5. When oil has drained completely, close the drain by installing the cap.

**Note:** Dispose of the used oil at a certified recycling center.

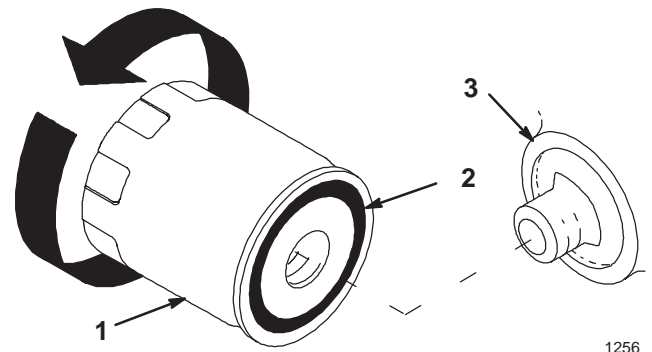




**Figure 25**

1. Oil drain cap

m-3386



**Figure 26**

1. Oil filter
2. Gasket
3. Adapter

1256

6. Slowly pour approximately 80% of the specified amount of oil into the filler tube (Fig. 24). Now check the oil level; refer to Checking Oil Level, page 24. Slowly add additional oil to bring to the full mark on dipstick.

## Changing the Oil Filter

### Service Interval/Specification

Replace the oil filter after every 200 hours or every other oil change.

**Note:** Change oil filter more frequently when operating conditions are extremely dusty or sandy.

1. Drain the oil from the engine; refer to Changing/Draining Oil, page 24.
2. Remove the old filter and wipe the filter adapter (Fig. 26) gasket surface.
3. Apply a thin coat of new oil to the rubber gasket on the replacement filter (Fig. 26).

4. Install the replacement oil filter to the filter adapter. Turn the oil filter clockwise until the rubber gasket contacts the filter adapter, then tighten the filter an additional 1/2 turn (Fig. 26).
5. Fill the crankcase with the proper type of new oil; refer to Changing/Draining Oil, page 24.

**Note:** Dispose of the used oil filter at a certified recycling center.

## Servicing the Spark Plug

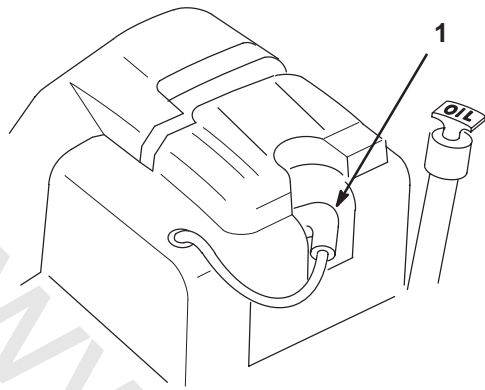
### Service Interval/Specification

Check the spark plug(s) after every 200 operating hours. Reset the gap or replace with a new plug as necessary. Make sure the air gap between the center and side electrodes is correct before installing the spark plug. Use a spark plug wrench for removing and installing the spark plug(s) and a gapping tool/feeler gauge to check and adjust the air gap.

Type: Champion RC12YC (or equivalent)  
 Champion Gold 2071  
 Air Gap: 0.040 in. (1.02 mm)

### Removing the Spark Plug(s)

1. Disengage the power take off (PTO), set the parking brake, and turn the ignition key to off. Remove the key.
2. Open the hood.
3. Pull the wire(s) off the spark plug(s) (Fig. 27). Now clean around the spark plug(s) to prevent dirt from falling into the engine and potentially causing damage.
4. Remove the spark plug(s) and metal washer.



m-3385

**Figure 27**

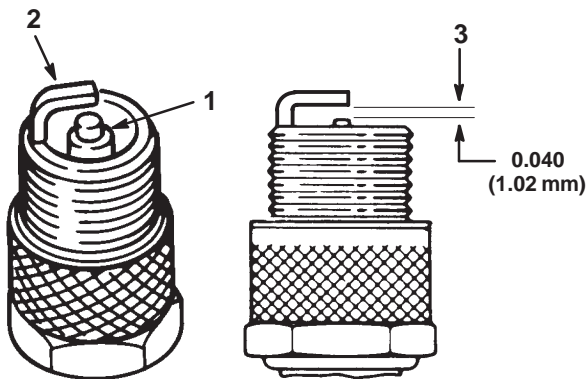
1. Spark plug wire

## Checking the Spark Plug

1. Look at the center of the spark plug(s) (Fig. 28). If you see light brown or gray on the insulator, the engine is operating properly. A black coating on the insulator usually means the air cleaner is dirty.

**Important** Never clean the spark plug(s). Always replace the spark plug(s) when it has: a black coating, worn electrodes, an oily film, or cracks.

2. Check the gap between the center and side electrodes (Fig. 28). Bend the side electrode (Fig. 28) if the gap is not correct.



**Figure 28**

1. Center electrode insulator
2. Side electrode
3. Air gap (not to scale)

## Installing the Spark Plug(s)

1. Install the spark plug(s) and metal washer. Make sure the air gap is set correctly.
2. Tighten the spark plug(s) to 30 ft. lb. (41 N·m).

3. Push the wire(s) onto the spark plug(s) (Fig. 27).
4. Close the hood.

## Greasing and Lubrication

### Service Interval/Specification

Grease the machine after every 50 operating hours or yearly, whichever occurs first. Grease more frequently when operating conditions are extremely dusty or sandy.

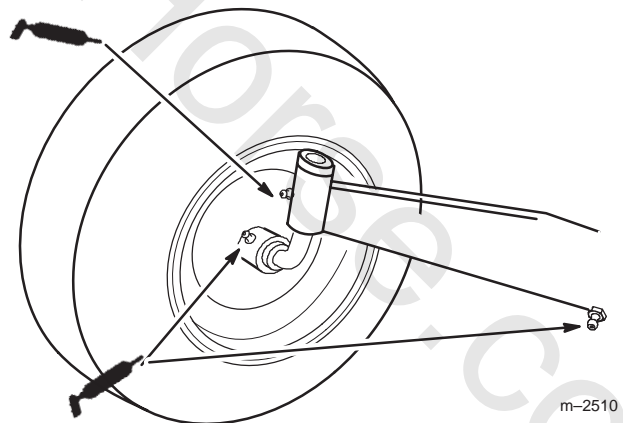
Grease Type: General-purpose grease.

### How to Grease

1. Disengage the power take off (PTO), set the parking brake, and turn the ignition key to off. Remove the key.
2. Clean the grease fittings with a rag. Make sure to scrape any paint off the front of the fitting(s).
3. Connect a grease gun to the fitting. Pump grease into the fittings until grease begins to ooze out of the bearings.
4. Wipe up any excess grease.

### Where to Add Grease

1. Lubricate the front wheels, spindles and tie-rod ends until grease begins to ooze out of the bearings (Fig. 29).
2. Lubricate the front axle pivot (Fig. 29).



m-2510

**Figure 29**

3. Lubricate the pedal(s) where it pivots on the mounting shaft, steering shaft and spread grease on steering sector teeth (Fig. 30).

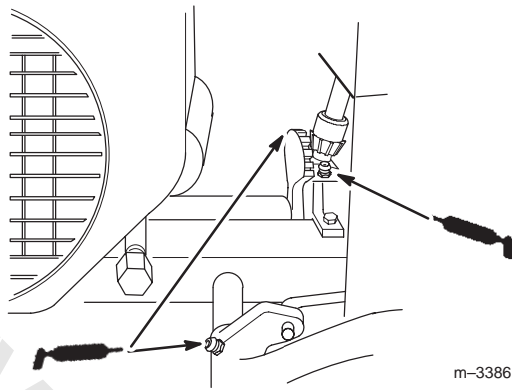


Figure 30

2. Blow out fins of engine and screen with compressed air. If area between screen and fins is tightly packed, remove engine shroud.

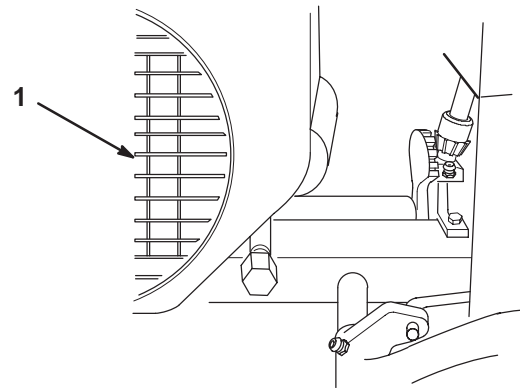


Figure 32

1. Engine air intake

## Checking the Tire Pressure

### Service Interval/Specification

Maintain the air pressure in the front and rear tires as specified. Check the pressure at the valve stem after every 25 operating hours or monthly, whichever occurs first (Fig. 31). Check the tires when they are cold to get the most accurate pressure reading.

Pressure: 12 psi (83 kPa) front and rear

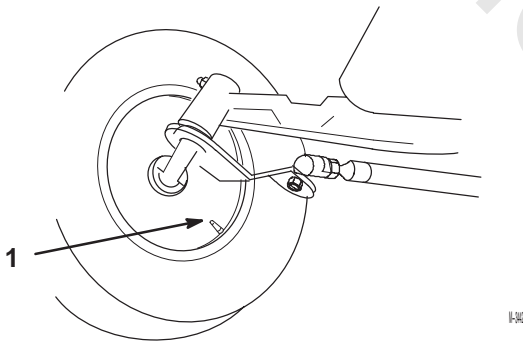


Figure 31

1. Valve stem

## Cleaning Engine Cooling Systems

Before each use, check and clean cooling screen. Remove any build-up of grass, dirt or other debris from the engine air intake. Every 100 hours clean engine cylinder and cylinder head cooling fins. Also clean around carburetor, governor levers and linkage. This will help insure adequate cooling to engine and will reduce the possibility of overheating and mechanical damage.

1. Clean off engine air intake (Fig. 32).

## Servicing the Brake

Always set the parking brake when you stop the machine or leave it unattended. If the parking brake does not hold securely, an adjustment is required.

### Checking the Brake

1. Park the machine on a level surface, disengage the power take off (PTO), set the parking brake, and turn the ignition key to off. Remove the key.
2. Place the gear shift in neutral. Rear wheels must lock and skid when you try to push the tractor forward. Adjustment is required if the wheels turn and do not lock; refer to Adjusting the Brake, page 27.
3. Release the parking brake and push the tractor. Wheels should rotate freely without brake drag.
4. If both conditions are met no adjustment is required.

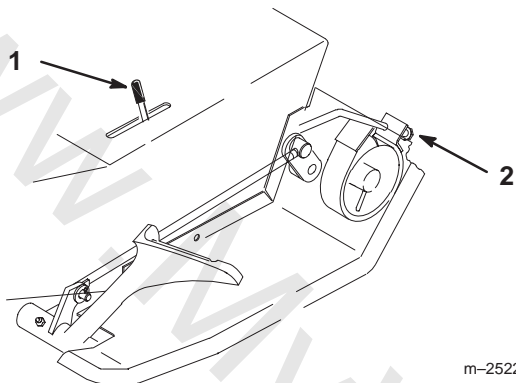
### Adjusting the Brake

The brake adjustment is behind the left side cover (Fig. 33). If the parking brake does not hold securely, an adjustment is required.

1. Check the brake before you adjust it; refer to Checking the Brake, page 27.
2. Set parking brake so latch is in second notch. To do this lift up on parking brake lever and slowly depress brake pedal and feel when latch is in second notch.
3. To adjust the brake tighten adjustment nut until rear wheels skid, then tighten an additional 1/2 turn (Fig. 33).

4. Check the brake operation again; refer to Checking the Brake, page 27.

**Important** With the parking brake released and the gear shift in neutral, the rear wheels must rotate freely when you push the tractor. If brake action and free wheel rotation cannot be achieved contact your service dealer immediately.



**Figure 33**

1. Parking brake lever
2. Adjustment nut

## Maintaining the Front Wheel Toe-In

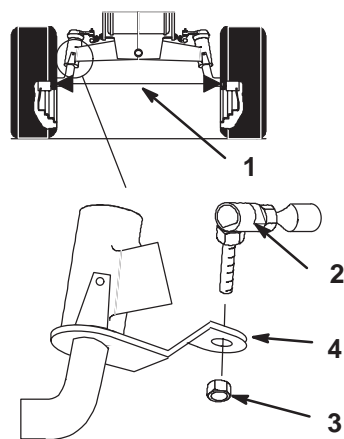
### Service Interval/Specification

Maintain toe-in of the front wheels as specified. If uneven tire wear, lawn scuffing or hard steering develop adjustment may be required. Check the toe-in after every 100 operating hours or yearly, whichever occurs first (Fig. 34).

Specification: 1/8–1/4 inch toe-in on front wheels.

### Measuring Toe-in

1. Disengage the power take off (PTO), set the parking brake, and turn the ignition key to off. Remove the key.
2. Push front tires out, at front, to remove normal looseness in the linkage.
3. Measure, between the rims, at spindle level, in the front and rear of the wheels (Fig. 34).
4. The front measurement should be less than the rear, as specified.



**Figure 34**

1. Measure here
2. Ball joint flats
3. Jam nut
4. Steering lever

### Adjusting Toe-In

1. Check the toe-in before you adjust it; refer to Measuring Toe-In, Page 28.
2. Remove ball joint from one steering lever (Fig. 34).
3. Loosen jam nut securing ball joint to steering rod. Rotate ball joint one turn, clockwise to decrease or counter clockwise to increase toe-in.
4. Install ball joint to steering lever and check the toe-in; refer to Measuring Toe-In, Page 28.

**Important** If more than one turn is required to meet specifications, alternate between left and right steering rods to maintain steering wheel alignment.

## Servicing the Fuel Tank

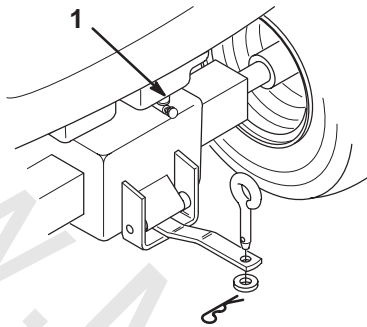
### Draining The Fuel Tank

⚠
Danger
⚠

**In certain conditions, gasoline is extremely flammable and highly explosive. A fire or explosion from gasoline can burn you and others and can damage property.**

- **Drain gasoline from the fuel tank when the engine is cold. Do this outdoors in an open area. Wipe up any gasoline that spills.**
- **Never smoke when draining gasoline, and stay away from an open flame or where a spark may ignite the gasoline fumes.**

1. Park the machine on a level surface, to assure fuel tank drains completely. Then disengage the power take off (PTO), set the parking brake, and turn the ignition key to off. Remove the key.
2. Close fuel shut-off valve at fuel tank (Fig. 35).



m-3396

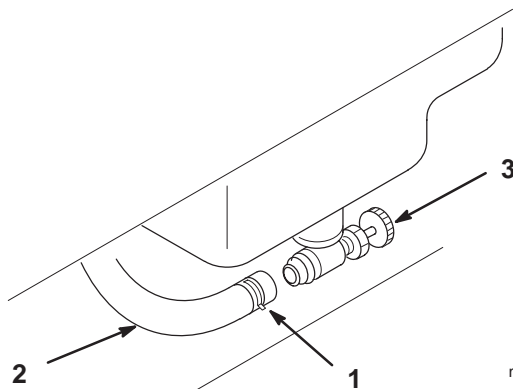
**Figure 35**

1. Fuel shut-off valve

3. Loosen the hose clamp and slide it up the fuel line away from the fuel shut-off valve (Fig. 36).
4. Pull the fuel line off fuel shut-off valve (Fig. 36). Open fuel shut-off valve and allow gasoline to drain into a gas can or drain pan.

**Note:** Now is the best time to install a new fuel filter because the fuel tank is empty.

5. Install the fuel line onto the fuel shut-off valve. Slide the hose clamp close to the fuel shut-off valve to secure the fuel line (Fig. 36).



m-2487

**Figure 36**

1. Hose clamp
2. Fuel line
3. Fuel shut-off valve

## Servicing the Transaxle Fluid

### Service Interval/Specification

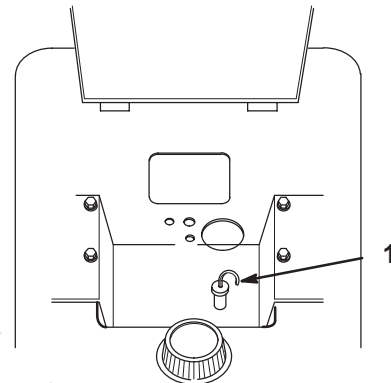
Check fluid level before every use. Always keep the fluid level at the full level when the transaxle is cold.

Fluid Type: SAE 90 gear lube (API service QL-5)

Capacity: 2 quarts (1.9 l)

### Checking Fluid Level

1. Park the machine on a level surface, disengage the power take off (PTO), set the parking brake, and turn the ignition key to off. Remove the key.
2. Tilt the seat up.
3. Clean around the transaxle dipstick (Fig. 37) so dirt cannot fall into the filler hole and damage the transaxle.



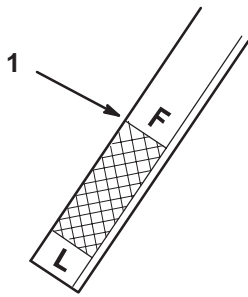
m-2512

**Figure 37**

1. Transaxle dipstick

4. Pull out the dipstick and wipe the metal end clean (Fig. 37).
5. Slide the dipstick fully into the filler tube (Fig. 24). Pull the dipstick out and look at the metal end. When transaxle is cold oil should be at the full line on the dipstick (Fig. 37).
6. If oil level is low, slowly pour only enough oil into the filler tube to raise the level to the full mark.

**Important** Do not fill above the full line as fluid may overflow when operating.



**Figure 38**

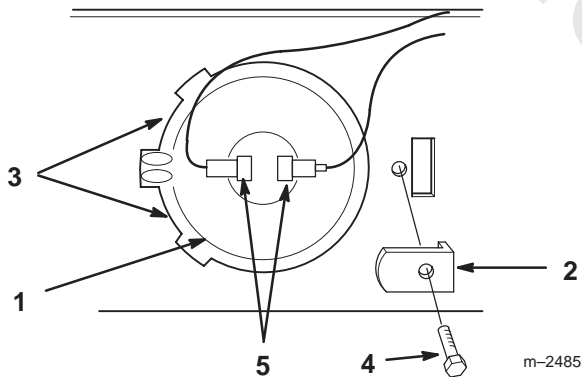
m-2467

1. Full cold level

## Servicing the Headlights

### Removing the Bulb

1. Disengage the power take off (PTO), set the parking brake, and turn the ignition key to off. Remove the key.
2. Open the hood. Pull wire connectors off light terminals.
3. Remove screw securing retainer bracket (Fig. 39).
4. Lift and twist bulb out of pocket (Fig. 39).



**Figure 39**

m-2485

- |                     |              |
|---------------------|--------------|
| 1. Bulb             | 4. Screw     |
| 2. Retainer bracket | 5. Terminals |
| 3. Tabs             |              |

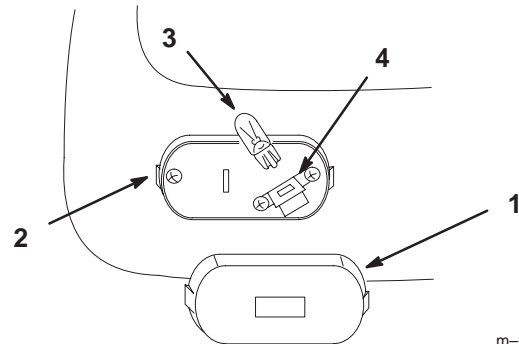
### Installing the Bulb

1. Locate index boss horizontal and twist bulb under tabs on left side of pocket (Fig. 39).
2. Hold bulb in socket with retainer bracket and secure with screw (Fig. 39).
3. Push wire connectors onto bulb terminals (Fig. 39).

## Servicing the Taillights

### Removing the Bulb

1. Disengage the power take off (PTO), set the parking brake, and turn the ignition key to off. Remove the key.
2. Inserting a screwdriver into slot and twist to remove lens (Fig. 40).
3. Pull bulb out of socket



m-2486

**Figure 40**

- |         |           |
|---------|-----------|
| 1. Lens | 3. Bulb   |
| 2. Slot | 4. Socket |

### Installing the Bulb

1. Align the bulb base with socket and push into position (Fig. 40).
2. Align and snap the lens onto the base (Fig. 40).

## Servicing the Battery

### **! WARNING**

**Battery posts, terminals, and related accessories contain lead and lead compounds, chemicals known to the State of California to cause cancer and reproductive harm. Wash hands after handling.**

### Service Interval/Specification

Check the electrolyte level in the battery every five hours. Always keep the battery clean and fully charged. Use a paper towel to clean the battery case. If the battery terminals are corroded, clean them with a solution of four parts water and one part baking soda. Apply a light coating of grease to the battery terminals to prevent corrosion.

## Removing the Battery

**Warning**

Battery terminals or metal tools could short against metal tractor components causing sparks. Sparks can cause the battery gasses to explode, resulting in personal injury.

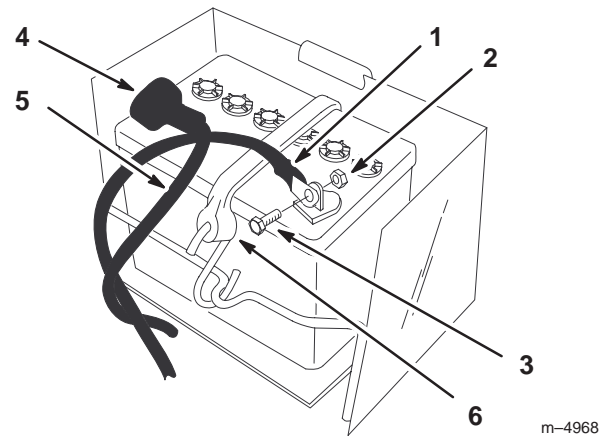
- When removing or installing the battery, do not allow the battery terminals to touch any metal parts of the tractor.
- Do not allow metal tools to short between the battery terminals and metal parts of the tractor.

**Warning**

Incorrect battery cable routing could damage the tractor and cables causing sparks. Sparks can cause the battery gasses to explode, resulting in personal injury.

- Always **DISCONNECT** the negative (black) battery cable before disconnecting the positive (red) cable.
- Always **RECONNECT** the positive (red) battery cable before reconnecting the negative (black) cable .

1. Disengage the power take off (PTO), set the parking brake, and turn the ignition key to off. Remove the key.
2. Open the hood and locate the battery.
3. Disconnect the negative (black) ground cable from the battery post (Fig. 41).
4. Lift the red rubber cover up on the positive cable. Disconnect the positive cable (red cover) from the battery post (Fig. 41).
5. Remove the battery hold down strap (Fig. 41). Remove battery from the tractor.



**Figure 41**

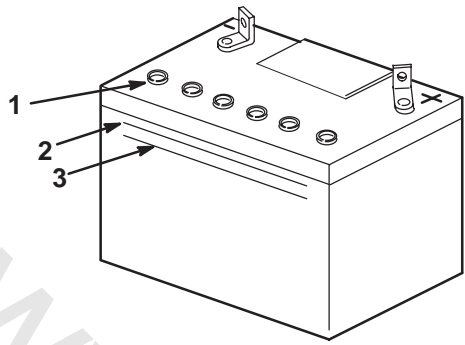
- |                   |                            |
|-------------------|----------------------------|
| 1. Negative cable | 4. Rubber cover (red)      |
| 2. Locknut        | 5. Positive cable          |
| 3. Bolt           | 6. Battery Hold Down Strap |

## Installing the Battery

1. Install the battery into the tractor (Fig. 41).
2. Secure battery with hold down strap (Fig. 41).
3. Using the bolt and nut, connect the positive (red cover) cable to the positive (+) battery post (Fig. 41). Slide the rubber cover over the battery post.
4. Using the bolt and nut, connect the negative (black) cable to the negative (-) battery post (Fig. 41).

## Checking Electrolyte Level

1. With the engine off, open the hood to locate the battery.
2. Look at the side of the battery. The electrolyte must be up to the upper line (Fig. 42). Do not allow the electrolyte to get below the lower line (Fig. 42).
3. If the electrolyte is low, add the required amount of distilled water; refer to Adding Water to the Battery, page 32.



**Figure 42**

1. Filler caps
2. UPPER line
3. LOWER line

**Warning**

**Battery electrolyte contains sulfuric acid which is a deadly poison and causes severe burns.**

- **Do not drink electrolyte and avoid contact with skin, eyes or clothing. Wear safety glasses to shield your eyes and rubber gloves to protect your hands.**
- **Fill the battery where clean water is always available for flushing the skin.**
- **Follow all instructions and comply with all safety messages on the electrolyte container.**

### Adding Water to the Battery

The best time to add distilled water to the battery is just before you operate the machine. This lets the water mix thoroughly with the electrolyte solution.

1. Remove the battery from the tractor.
2. Clean the top of the battery with a paper towel.

**Note:** Never fill the battery with distilled water while the battery installed in the tractor. Electrolyte could be spilled on other parts and cause corrosion.

3. Remove the vent caps from the battery (Fig. 42).
4. Slowly pour distilled water into each battery cell until the level is up to the upper line (Fig. 42) on the battery case.

**Important** Do not overfill the battery because electrolyte (sulfuric acid) can cause severe corrosion and damage to the chassis.

5. Wait five to ten minutes after filling the battery cells. Add distilled water, if necessary, until the electrolyte level is up to the upper line (Fig. 42) on the battery case.
6. Reinstall battery vent caps.

### Charging the Battery

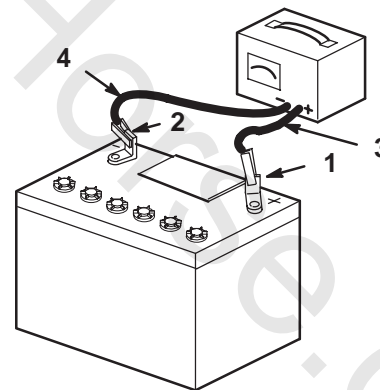
**Warning**

**Charging the battery produces gasses that can explode.**

**Never smoke near the battery and keep sparks and flames away from battery.**

**Important** Always keep the battery fully charged (1.265 specific gravity). This is especially important to prevent battery damage when the temperature is below 32°F (0°C).

1. Remove the battery from the chassis; refer to Removing the Battery, page 31.
2. Check the electrolyte level; refer to Checking Electrolyte Level, page 31.
3. Make sure the filler caps are installed in battery. Charge battery for 10 to 15 minutes at 25 to 30 amps or 30 minutes at 4–6 amps.
4. When the battery is fully charged, unplug the charger from the electrical outlet, then disconnect the charger leads from the battery posts (Fig. 43).



**Figure 43**

1. Positive Battery Post
2. Negative Battery Post
3. Red (+) Charger Lead
4. Black (-) Charger Lead

5. Install the battery in the tractor and connect the battery cables; refer to Installing the Battery on page 31.



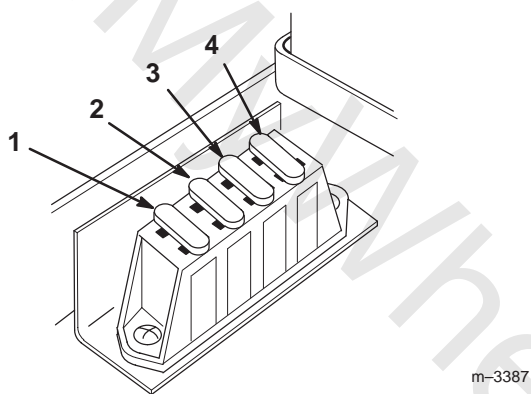
**Note:** Do not run the tractor with the battery disconnected, electrical damage may occur.

## Servicing the Fuse

### Service Interval/Specification

The electrical system is protected by fuses. It requires no maintenance, however, if a fuse blows check component/circuit for malfunction or short. To replace fuses pull up on the fuse (Fig. 44) to remove or replace it.

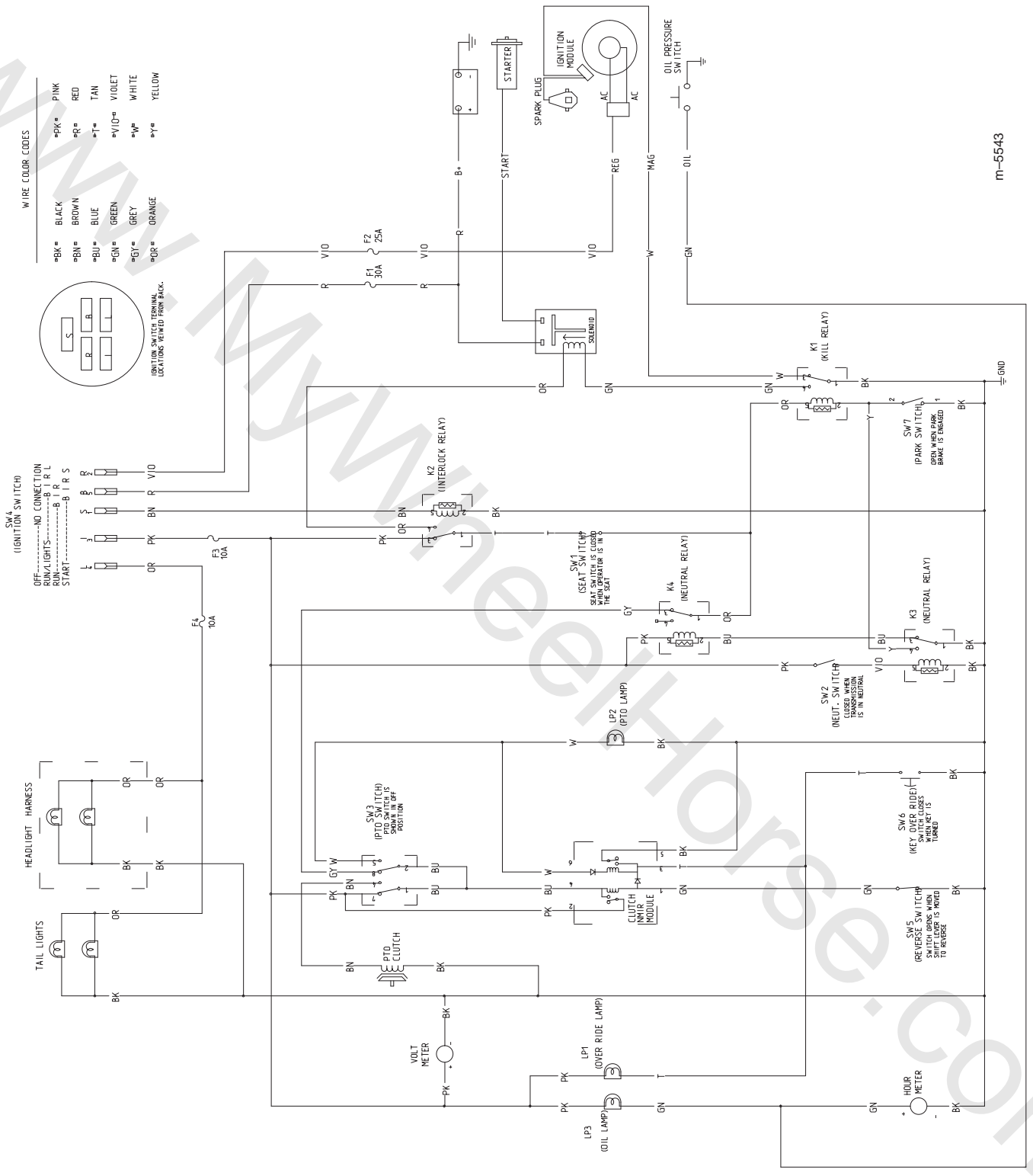
Fuse: Main F1-30 amp, blade-type  
Alternator F2-25 amp, blade-type  
Safety system F3-10 amp, blade-type  
Lights F4-10 amp, blade-type



**Figure 44**

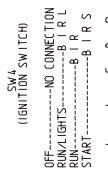
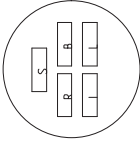
- |                      |                         |
|----------------------|-------------------------|
| 1. Main-30 amp       | 3. Safety system-10 amp |
| 2. Alternator-25 amp | 4. Lights-10 amp        |

# Wiring Diagram



WIRE COLOR CODES

•BK = BLACK	•PK = PINK
•BN = BROWN	•RR = RED
•BU = BLUE	•TAN = TAN
•GN = GREEN	•VIO = VIOLET
•GY = GREY	•W = WHITE
•OR = ORANGE	•Y = YELLOW



m-5543

## Cleaning and Storage

1. Disengage the power take off (PTO), set the parking brake, and turn the ignition key to off. Remove the ignition and KeyChoice keys.
2. Remove grass clippings, dirt, and grime from the external parts of the entire machine, especially the engine. Clean dirt and chaff from the outside of the engine's cylinder head fins and blower housing.

**Important** You can wash the machine with mild detergent and water. Do not pressure wash the machine. Avoid excessive use of water, especially near the control panel, lights, engine, and the battery.

3. Check the brake; refer to Servicing the Brake, page 27.
4. Service the air cleaner; refer to Servicing the Air Cleaner, page 23.
5. Grease the chassis; refer to Greasing and Lubrication, page 26.
6. Change the crankcase oil and filter; refer to Servicing the Engine Oil, page 24.
7. Check the tire pressure; refer to Checking the Tire Pressure, page 27.
8. Prepare the machine for storage when non-use occurs over 30 days. Prepare machine for storage as follows.
  - A. Add a petroleum based stabilizer/conditioner to fuel in the tank. Follow mixing instructions from stabilizer manufacture. **Do not use an alcohol based stabilizer (ethanol or methanol).**

**Note:** A fuel stabilizer/conditioner is most effective when mixed with fresh gasoline and used at all times.

- B. Run engine to distribute conditioned fuel through the fuel system (5 minutes).
- C. Stop engine, allow to cool and drain the fuel tank; refer to Servicing the Fuel Tank, page 28.

- D. Restart engine and run it until it stops.
- E. Choke or prime the engine. Start and run engine until it will not start. Operate primer, if equipped on machine, several times to ensure fuel remains in primer system.
- F. Dispose of fuel properly. Recycle as per local codes.

**Important** Do not store stabilizer/conditioned gasoline over 90 days.

9. Remove the spark plug(s) and check its condition; refer to Servicing the Spark Plug, page 25. With the spark plug(s) removed from the engine, pour two tablespoons of engine oil into the spark plug hole. Now use the electric starter to crank the engine and distribute the oil inside the cylinder. Install the spark plug(s) and tighten it to 30 ft-lb (40 Nm). Do not install the wire on the spark plug(s).

10. Disconnect the negative battery cable. Clean the battery and battery terminals. Check the electrolyte level and charge it fully; refer to Servicing the Battery on page 30. Leave the negative battery cable disconnected from the battery during storage.

**Important** The battery must be fully charged to prevent it from freezing and being damaged at temperatures below 32°F (0°C). A fully charged battery can be stored one winter season without recharging.

11. Check and tighten all bolts, nuts, and screws. Repair or replace any part that is damaged or defective.
12. Paint all scratched or bare metal surfaces. Paint is available from your Authorized Service Dealer.
13. Store the machine in a clean, dry garage or storage area. Remove the keys from the ignition and KeyChoice switches and keep it in a memorable place. Cover the machine to protect it and keep it clean.

# Troubleshooting

PROBLEM	POSSIBLE CAUSES	CORRECTIVE ACTION
Starter does not crank	<ol style="list-style-type: none"> <li>1. Blade control (PTO) is engaged.</li> <li>2. Parking brake is not on.</li> <li>3. Operator is not seated.</li> <li>4. Speed selector is not in N or neutral.</li> <li>5. Battery is dead.</li> <li>6. Electrical connections are corroded or loose.</li> <li>7. Fuse is blown.</li> <li>8. Relay or switch is defective.</li> </ol>	<ol style="list-style-type: none"> <li>1. Move blade control (PTO) to disengaged.</li> <li>2. Set parking brake.</li> <li>3. Sit on the seat.</li> <li>4. Move speed selector to N or neutral.</li> <li>5. Charge the battery.</li> <li>6. Check electrical connections for good contact.</li> <li>7. Replace fuse.</li> <li>8. Contact Authorized Service Dealer.</li> </ol>
Engine will not start, starts hard, or fails to keep running.	<ol style="list-style-type: none"> <li>1. Fuel tank is empty.</li> <li>2. Choke is not on.</li> <li>3. Air cleaner is dirty.</li> <li>4. Spark plug wire is loose or disconnected.</li> <li>5. Spark plug is pitted, fouled, or gap is incorrect.</li> <li>6. Dirt in fuel filter.</li> <li>7. Dirt, water, or stale fuel is in fuel system.</li> </ol>	<ol style="list-style-type: none"> <li>1. Fill fuel tank with gasoline.</li> <li>2. Move choke lever to on.</li> <li>3. Clean or replace air cleaner element.</li> <li>4. Install wire on spark plug.</li> <li>5. Install new, correctly gapped spark plug.</li> <li>6. Replace fuel filter.</li> <li>7. Contact Authorized Service Dealer.</li> </ol>
Engine loses power.	<ol style="list-style-type: none"> <li>1. Engine load is excessive.</li> <li>2. Air cleaner is dirty.</li> <li>3. Oil level in crankcase is low.</li> <li>4. Cooling fins and air passages under engine blower housing are plugged.</li> <li>5. Spark plug is pitted, fouled, or gap is incorrect.</li> <li>6. Vent hole in fuel cap is plugged.</li> <li>7. Dirt in fuel filter.</li> <li>8. Dirt, water, or stale fuel is in fuel system.</li> </ol>	<ol style="list-style-type: none"> <li>1. Shift into lower gear to reduce ground speed.</li> <li>2. Clean air cleaner element.</li> <li>3. Add oil to crankcase.</li> <li>4. Remove obstruction from cooling fins and air passages.</li> <li>5. Install new, correctly gapped spark plug.</li> <li>6. Clean or replace the fuel cap.</li> <li>7. Replace fuel filter.</li> <li>8. Contact Authorized Service Dealer.</li> </ol>

<b>PROBLEM</b>	<b>POSSIBLE CAUSES</b>	<b>CORRECTIVE ACTION</b>
Engine overheats.	<ol style="list-style-type: none"> <li>1. Engine load is excessive.</li> <li>2. Oil level in crankcase is low.</li> <li>3. Cooling fins and air passages under engine blower housing are plugged.</li> </ol>	<ol style="list-style-type: none"> <li>1. Shift into lower gear to reduce ground speed.</li> <li>2. Add oil to crankcase.</li> <li>3. Remove obstruction from cooling fins and air passages.</li> </ol>
Abnormal vibration.	<ol style="list-style-type: none"> <li>1. Engine mounting bolts are loose.</li> <li>2. Loose engine pulley, idler pulley, or blade pulley.</li> <li>3. Engine pulley is damaged.</li> </ol>	<ol style="list-style-type: none"> <li>1. Tighten engine mounting bolts.</li> <li>2. Tighten the appropriate pulley.</li> <li>3. Contact Authorized Service Dealer.</li> </ol>
Machine does not drive.	<ol style="list-style-type: none"> <li>1. Traction belt is worn, loose or broken.</li> <li>2. Traction belt is off pulley.</li> <li>3. Transmission does not shift.</li> </ol>	<ol style="list-style-type: none"> <li>1. Contact Authorized Service Dealer.</li> <li>2. Contact Authorized Service Dealer.</li> <li>3. Contact Authorized Service Dealer.</li> </ol>

[www.MyWheelHorse.com](http://www.MyWheelHorse.com)

[www.MyWheelHorse.com](http://www.MyWheelHorse.com)



Consumer  
Lawn Tractors  
and  
Lawn & Garden  
Tractors

## The Toro Total Coverage Guarantee

### A Two-Year Full Warranty (Limited Warranty for Commercial Use)

#### Conditions and Products Covered

The Toro Company and its affiliate, Toro Warranty Company, pursuant to an agreement between them, jointly promise to repair any Toro Product used for normal residential purposes\* if defective in materials or workmanship. The following time periods apply from the date of purchase:

<u>Products</u>	<u>Warranty Period</u>
• All Products and Attachments	2 year full warranty
• 300, 400XT, and 5xi Series:	
Frame	5 year full warranty
Front Axle	5 year full warranty
Drive Shaft (5xi Series Only)	5 year full warranty
• All Batteries	1 year full warranty

This warranty covers both the cost of parts and labor, and transportation within a fifteen mile radius of the servicing dealer.

This warranty applies to all consumer Lawn Tractors, Lawn and Garden Tractors, and their attachments.

\* Normal residential purposes means use of the product on the same lot as your home. Use at more than one location is considered commercial use, and the commercial use warranty would apply.

#### Limited Warranty for Commercial Use

Toro Consumer Products and attachments used for commercial, institutional, or rental use are warranted against defects in materials or workmanship for the following time periods from the date of purchase:

<u>Products</u>	<u>Warranty Period</u>
• 300, 400XT, and 5xi Series:	
Liquid Cooled Gas Engines	1 year limited warranty
Air Cooled Gas and Diesel Engines	2 year limited warranty
All other items	1 year limited warranty
• All other Lawn Tractors and Lawn & Garden Tractors	90 day limited warranty

#### Instructions for Obtaining Warranty Service

If you think that your Toro Product contains a defect in materials or workmanship, follow this procedure:

1. Contact any Toro Authorized or Master Service Dealer to arrange service at their dealership. To locate a dealer convenient to you, refer to the Yellow Pages of your telephone directory (look under "Lawn Mowers") or access our website at [www.Toro.com](http://www.Toro.com). U.S. Customers may also call toll free: 866-854-9035 to use our 24-hour Toro dealer locator system.
2. Bring the product and your proof of purchase (sales receipt) to the Service Dealer.

#### Countries Other than the United States or Canada

Customers who have purchased Toro products exported from the United States or Canada should contact their Toro Distributor (Dealer) to obtain guarantee policies for your country, province, or state. If for any reason you are dissatisfied with your Distributor's service or have difficulty obtaining guarantee information, contact the Toro importer. If all other remedies fail, you may contact us at Toro Warranty Company.

If for any reason you are dissatisfied with the Service Dealer's analysis or with the assistance provided, contact us at:

Customer Care Department, Consumer Division  
Toro Warranty Company  
8111 Lyndale Avenue South  
Bloomington, MN 55420-1196  
Toll Free: 866-854-8930 (U.S. customers)  
Toll Free: 866-854-9033 (Canada customers)

#### Owner Responsibilities

You must maintain your Toro Product by following the maintenance procedures described in the operator's manual. Such routine maintenance, whether performed by a dealer or by you, is at your expense.

#### Items and Conditions Not Covered

There is no other express warranty except for special emission system coverage on some products. This express warranty does not cover:

- Cost of regular maintenance service or parts, such as filters, fuel, lubricants, tune-up parts, blade sharpening, brake and clutch adjustments.
- Any product or part which has been altered or misused or required replacement or repair due to normal wear, accidents, or lack of proper maintenance.
- Repairs necessary due to improper fuel, contaminants in the fuel system, or failure to properly prepare the fuel system prior to any period of non-use over three months.
- Pickup and delivery charges for distances beyond a fifteen mile radius from an Authorized Toro Service Dealer.

All repairs covered by this warranty must be performed by an Authorized Toro Service Dealer using Toro approved replacement parts.

#### General Conditions

Repair by an Authorized Toro Service Dealer is your sole remedy under this warranty.

Neither The Toro Company nor Toro Warranty Company is liable for indirect, incidental or consequential damages in connection with the use of the Toro Products covered by this warranty, including any cost or expense of providing substitute equipment or service during reasonable periods of malfunction or non-use pending completion of repairs under this warranty.

Some states do not allow exclusions of incidental or consequential damages, or limitations on how long an implied warranty lasts, so the above exclusions and limitations may not apply to you.

This warranty gives you specific legal rights, and you may also have other rights which vary from state to state.