



Wheel Horse

Service Bulletin

13

April 28, 1960

TO ALL DEALERS & DISTRIBUTORS:

SUBJECT: RMR 32-60 ROTARY MOWER

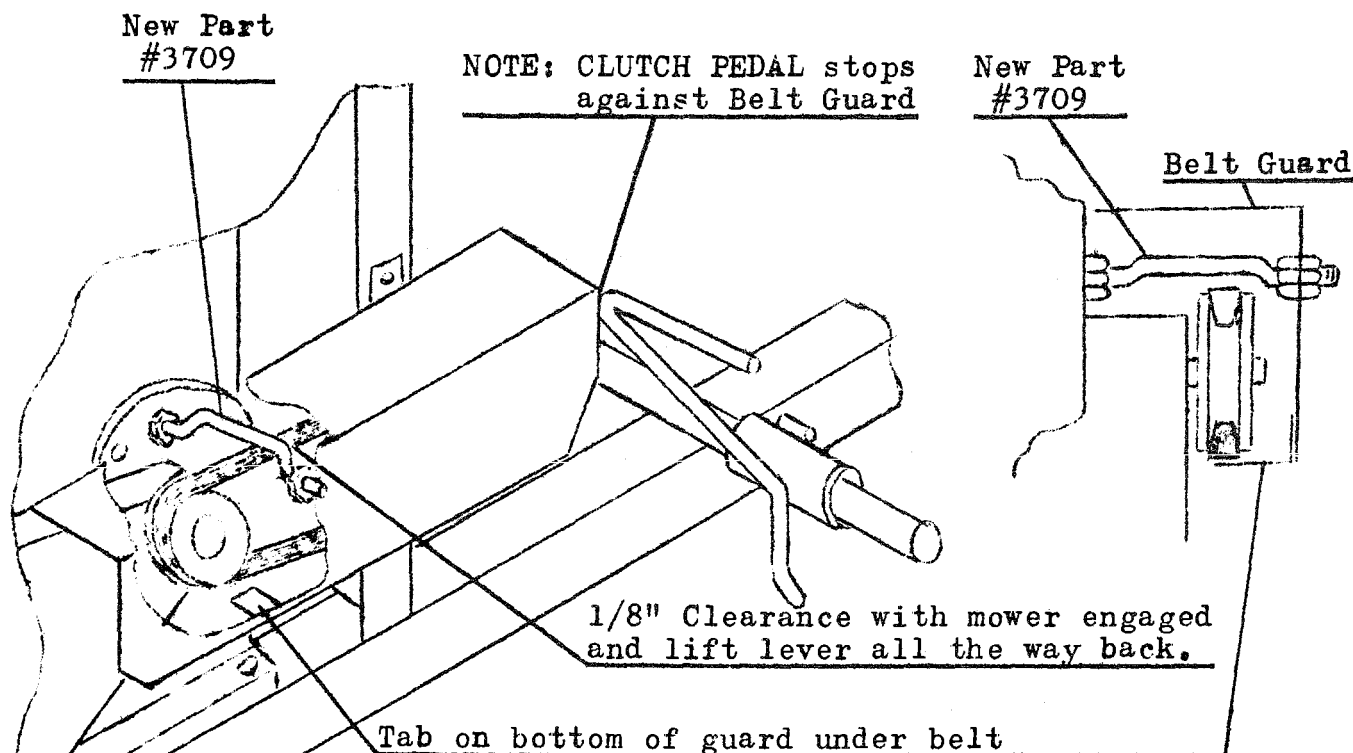

In cases of excessive belt wear of the 30" belt on the rotary mower, a check should be made to be sure that the tube, guard mount, part #3182 is not rubbing on the belt. In the event it is rubbing, a new part #3709 is available at no charge, which will rectify this problem. It should be installed as shown in the cutaway view and be adjusted by turning the bolt so that there is 1/8" clearance with the mower belt engaged (TIGHT) and the lift lever all the way back.

V-Belts are subject to an initial stretch, therefore, belts should be checked for proper tension during the first hour of operation.

Be sure and install belt guard with belt engaged to eliminate the possibility of getting the belt on the outside of the tab on the bottom of the guard.

RH Mounting
Angle Assembly
#3191

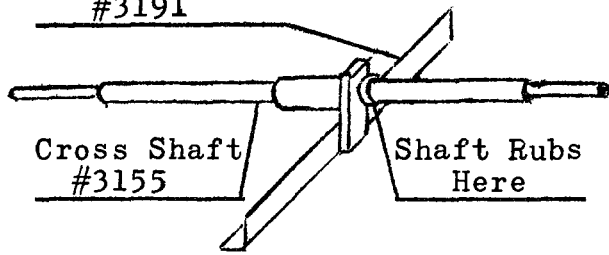

NOTE: The RH Mounting angle assembly, part #3191, in some cases rubs against the cross shaft, #3155, and causes friction.

A few drops of oil will usually rectify this problem, but in the event of excessive friction, part #3191 will be replaced under warranty.

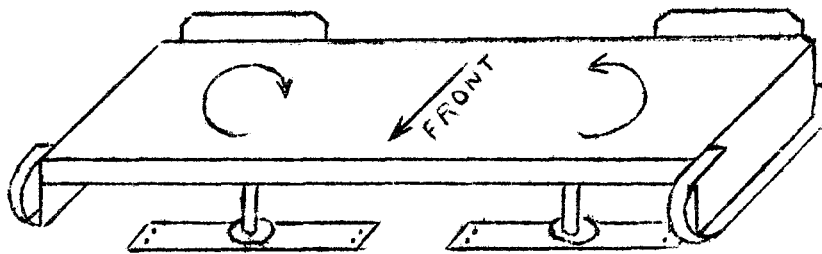

RIGHT SPINDLE

LEFT SPINDLE



#3133R Blade Tip



#3133L Blade Tip

To properly install the blade tips on the rotary mower, fasten the two #3133R blade tips on the right spindle and the two #3133L blade tips on the left spindle.

NOTE: Reversed blade tips will leave center strip uncut and will leave cut grass with torn look.

Donald J. Palbykin

Donald J. Palbykin
Service Manager