

# PARTS LIST AND INSTRUCTIONS



## WHEEL HORSE

WHEEL-HORSE PRODUCTS, INC. • SOUTH BEND, IND.

# ROTARY MOWER

## MODELS

5-1010 – 42"

5-1210 – 48"

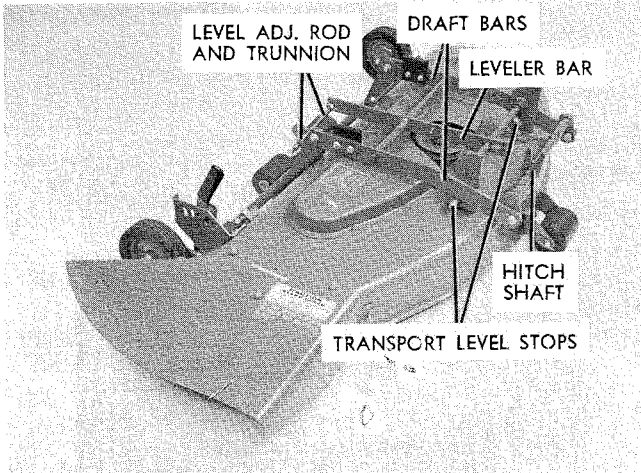

Fig. 1 – 42" Mower Assembly

The 48" model mower is recommended for use on 1973 12-14 & 16 HP models.

The 42" 1973 model is recommended for 10-12-14 & 16 HP models.

They may be adapted to other models in the above HP ranges as follows:

1972 Long Frames – Use #8-5541 Hitch Accessory.  
1971 & Prior Long Frames – Use #8-5551 Hitch Accessory.

## MOWER INSTALLATION

Turn the front wheels of the tractor fully to the left. The mower is installed from the right side.

Place the mower at the right side of the tractor with the gage wheels in the lowest cutting height.

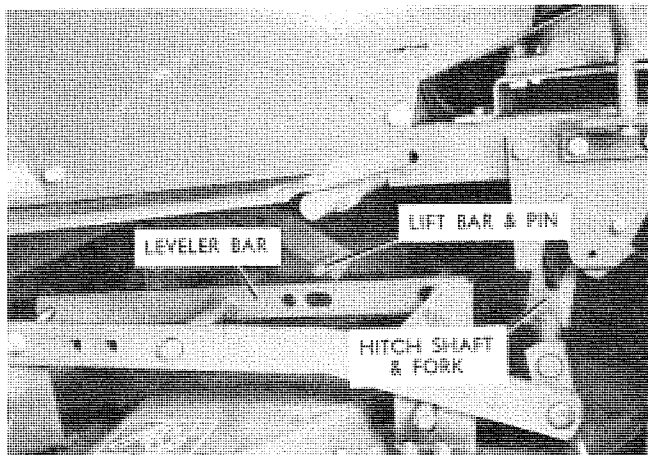

Fig. 3 – Mower Installation from Right Side

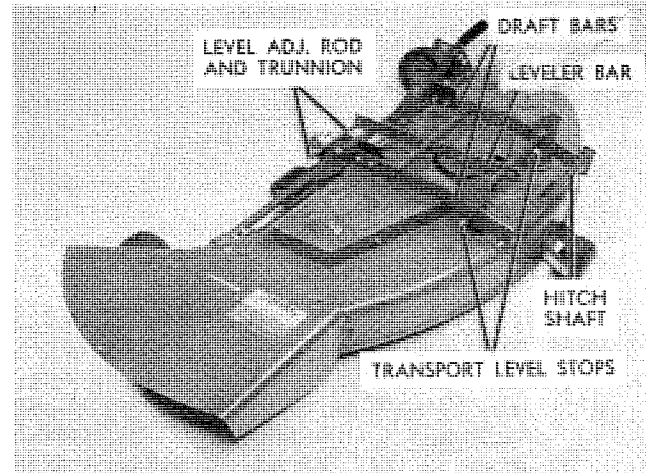

Fig. 2 – 48" Mower Assembly

With the tractor lift lever pulled back, slide the mower part way under the tractor sufficiently to allow the tractor lift bar to clear the left draft bar.

Push the lift lever forward far enough to line up the pin of the lift bar with the slotted hole in the leveler bar of the mower. (Fig. 3.)

Slide the mower under the tractor until it is centered making sure that the lift pin is in the slot of the leveler bar.

From the left side of the tractor open the mid-hitch latch.

With the fork of the mower hitch shaft pointing upward so that the fork will engage around the latch shaft, use the lift lever to lift the mower hitch shaft and draft bars upward and insert the mower hitch shaft into the hitch slots, and lock with the latch. (Figs. 3 & 4.)

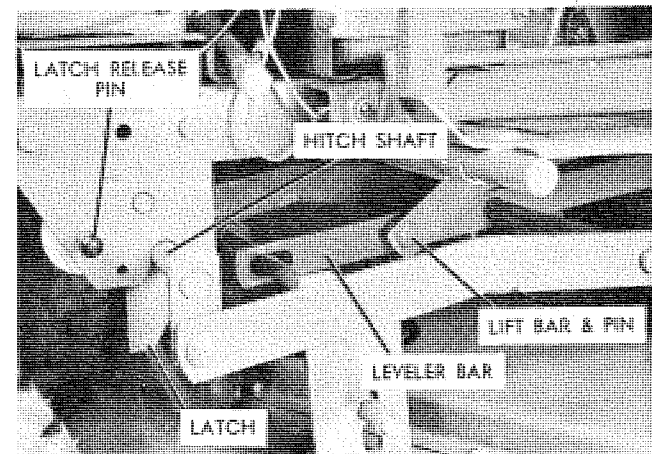
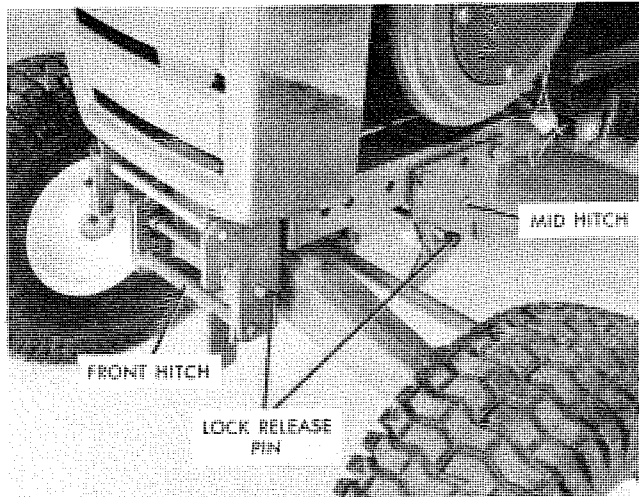

Fig. 4 – Mower Installation from Left Side

**Note:** The locating spacers welded to the mower hitch shaft must be positioned between the tractor hitch plates.



**Fig. 5 — Front & Mid Hitch**

### FRONT PULLEY SUPPORT & BELT INSTALLATION

Unlock and release the front hitch assembly. This is easily done by pushing in on the latch pin and pulling forward on the latch handle. (This leaves the hitch slots open so the shaft of the pulley support can be inserted.) (Fig. 5.)

Turn the belt adjustment knob all the way clockwise.

Insert the shaft of the pulley support assembly into the hitch slots and push the latch handle to the rear to lock the latch.

Remove the pulley cover retaining nut and remove the cover. Reinstall the nut finger tight to keep the pulleys and spacers from coming off the shaft.

Install the belt in the groove of the mower pulley and lead the belt strands around the idler pulleys with the inside strand in the V pulley and the outside

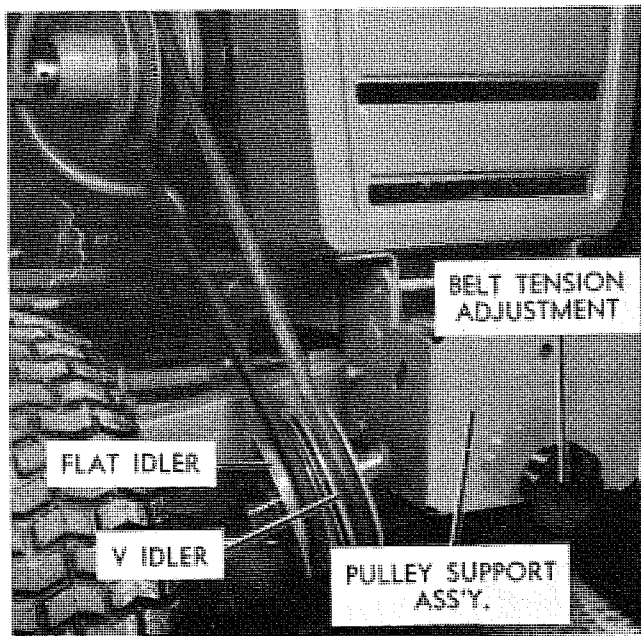

**Fig. 6 — Installation — Pulley Support & Drive Belt**

strand making a back bend around the flat idler. (Fig. 6.)

Place belt on inside groove of PTO clutch pulley. REFERENCE ATTACHMENT BELT SECTION OF TRACTOR OWNER'S MANUAL.

Holding the belt in against the thrust collar, adjust the belt by turning the adjusting knob counter-clockwise until the two strands of the belt can just be squeezed together with the thumb and forefinger midpoint between the V idler pulley and the PTO clutch pulley.

Remove the pulley cover retaining nut and install the cover making sure to insert the cover pilot pin in the slot of the support assembly. Reinstall the cover retaining nut and tighten. (Fig. 7.)

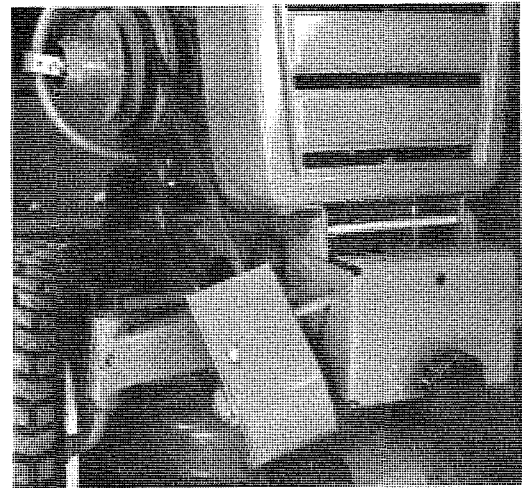

**Fig. 7 — Mower & Pulley Support Installed**

### MOWER REMOVAL

Set the mower gage wheels in the lowest cutting position and lower the mower with the lift lever. Turn the front wheels all the way to the left.

Turn the belt adjustment knob clockwise all the way to loosen the belt and remove the belt from the mower pulley.

Push the mid-hitch lock release pin and open the latch, releasing the mower hitch shaft.

Slide the mower out the right side until the lift bar pin comes out of the slot in the leveler bar.

Raise the lift lever and slide the mower out from under the tractor.

If desired, the pulley support and belt assembly may easily be removed by pushing in on the release lock pin, and pulling the latch handle forward which allows removal of the support assembly from the hitch. Remove the belt from the PTO clutch pulley.

### OPERATION

1. Lift the mower with the tractor lift lever to remove weight of the mower from the gage wheels. **Note:** Never stand on the mower.

2. Move the height control to the hole on the quadrant corresponding to the desired cutting height. The recommended cutting height is two to three inches.

3. Disengage the power take-off clutch and lower the mower before starting the tractor engine.

4. Start the engine and engage the power take-off clutch. For best cutting results on average level

lawns, operate the tractor at full throttle in 2nd gear. Uneven cutting often results from excessive ground speed. To correct, reduce ground speed with transmission while maintaining full throttle.

5. To mow extra tall grass, raise the mower to the highest position for the first cut using the lowest drive speed. Then recut to normal height.

**Note:** For best belt life the PTO clutch should be engaged and disengaged with the engine operating at normal mowing speeds. Low speed engagement and disengagement tends to cause excessive belt whipping resulting in reduced belt life.

## MAINTENANCE

### Lubrication

The gage wheels should be lubricated with a pressure grease gun using automotive chassis lubricant after every 8 to 10 hours of operation. All pulleys and spindle assemblies are lubricated at the factory and require no further lubrication.

**IMPORTANT** — Clean the underside of the mower deck frequently to prevent the accumulation of matted clippings which seriously impair the mower's ability to lift grass blades upright into cutting position and to discharge clippings evenly.

### Blade Maintenance:

Invert the mower. Remove the three blade attaching bolts and special washers. Lift the blades off the spindles.

File or grind the blades evenly, taking care to retain the original cutting edge angle and blade balance. Reinstall the blades, making sure the pins protruding from the spindle cups engage the blade properly. The side of the blade with the lift area (turned up section) must be installed facing the mower deck. Tighten the blade attaching screws to a torque of 30 Ft./Lbs. These screws, Part No. 908033-6 should be replaced after every two or three times they are removed and reinstalled.

## REPLACEMENT BELTS

Be sure to purchase genuine Wheel Horse belts for replacement purposes as these belts are designed specifically for each application.

## MOWER DRIVE BELT REPLACEMENT

Turn belt adjustment knob all the way clockwise.

Remove the belt cover retaining nut and remove the cover being careful not to lose pulley-cover spacer. Reinstall the nut finger tight to avoid the possibility of the pulleys and spacers coming off.

Remove the belt from the PTO, mower and idler pulleys and examine the condition of the pulleys making sure the pulley grooves and bearings are in good condition.

Install the replacement belt in the mower pulley groove and lead the belt strands around the idler pulleys with the inside strand in the V pulley and the outside strand making a back bend around the flat idler and install on inside groove of PTO pulley.

Holding the pulleys in against thrust collar, adjust the belt by turning the adjusting knob counter-clockwise until the two strands of the belt can just be

squeezed together with thumb and forefinger at the midpoint between the V idler pulley and the PTO clutch pulley.

Remove the pulley cover retaining nut keeping pulley spacer on shaft and install the cover making sure to insert the cover pilot pin in the slot of the support assembly. Reinstall the cover retaining nut and tighten.

## SPINDLE BELT REPLACEMENT

Remove the mower from the tractor.

Remove the level adjustment rod from the rear of the adjustment bar.

Remove the bolts, nuts, and spacers that fasten the two draft bars to the rear brackets.

Swing the draft and leveler bars forward out of the way and remove the belt cover nuts or bolts and lift the cover off the mower deck.

Remove the old belt and install the new belt in accordance with the belt diagram on the belt cover. Make sure the pulley area is clean and the idler slide bar is free. Examine the spring to make sure it is in good shape and in place.

Reinstall the belt cover and fasten the draft bars to the brackets making sure the spacers are seated correctly.

Reinstall the level adjustment rod and secure with the hairpin cotter.

## CHECKING MOWER LEVEL

For optimum efficiency the level of the mower should be checked at the time of initial installation and periodically as a check to see if alignment is maintained.

Place gage wheel lever pin in the center hole of the quadrant making sure the lift lever is released and the tractor is on a good level floor with the tires inflated properly.

Place a level on a flat area of the mower deck from front to back.

Adjust until the deck is level from front to back with the adjustment nut on the level adjustment rod which connects the back of the lift bar to the gage wheel support lever, **then back the nut off one (1) complete turn** which will lower the front of the mower slightly. **Note: The trunnion must always be installed in the hole nearest to the gage wheel support shaft.**

## TRACTOR LIFT BAR — TRUNNION & LIFT ROD ADJUSTMENT

This adjustment involves parts on the tractor. With the lift lever latched in the full up position the #6739 Trunnion on the lift rod should be adjusted so that the bumpers on the draft bars of the mower suspension come in contact with the foot rests, with the Trunnion Stud in the rear hole of the lift lever.

## TRANSPORT LEVEL STOP ADJUSTMENT

For normal operation the level stops should be adjusted so that the carriage bolt heads are set at the bottom of the bracket slots.

**Note:** If the mower does not cut level in the transport position the level stops may be adjusted by moving them in their bracket slots as required.

## PARTS LIST FOR ROTARY MOWER

Parts available only through Authorized Dealers.

When ordering parts always list Part No. and name of Part.

(Specifications subject to change without notice.)

Item No.	Part No.	Description	No. Req'd.		Item No.	Part No.	Description	No. Req'd.	
			42" 5-1010	48" 5-1210				42" 5-1010	48" 5-1210
1	102660	Deck — 42"	1	0	53	101776	Bracket — R.H. Rear	0	1
1	102760	Deck — 48"	0	1	54	102429	Bracket — L.H. Rear	1	0
2	6759	Support — Deck	0	1	54	101775	Bracket — L.H. Rear	0	1
3	900062-4	Bolt — 3/8-16 x 3/4 Carriage	0	1	55	900062-4	Bolt — 3/8-16 x 3/4 Carriage	4	4
4	915663-4	Nut — E.S. 3/8-16	0	1	56	915113-6	Nut — 3/8-16 Eslok	4	4
5	102776	Spindle Assy.	3	3	57	102574	Bracket — R.H. Front	1	1
6	908033-6	Bolt — 3/8-16 x 7/8 Nylock	12	12	58	102575	Bracket — L.H. Front	1	1
7	6692	Pulley — Center	1	0	59	900062-4	— 3/8-16 x 3/4 Carriage	4	4
7	6756	Pulley — Center	0	1	60	915113-6	Nut — 3/8-16 Eslok	4	4
8	5877	Pulley — Right & Left	2	0	61	6595	Spacer — Level Stop	2	2
8	6757	Pulley — Right & Left	0	2	62	900093-4	Bolt — 7/16-14 x 1 1/2	2	2
9	908032-6	Bolt — 3/8-16 x 3/4 Nylock	3	3	63	915664-4	Nut — 1/16-14 E.S.	2	2
10	2844	Washer — Special	3	3	64	102385	Rod — Leveler	1	0
11	102784	Cup — Spindle	3	3	64	102035	Rod — Leveler	0	1
12	933210	Spirol Pin — 1/4 x 5/8	6	6	65	6739	Trunnion	1	1
13	6693	Blade — 14"	3	0	66	915663-4	Nut — 3/8-16 E.S.	1	1
13	6758	Blade — 16"	0	3	67	933504-4	Hairpin	2	2
14	1336	Washer — Dome	3	3	68	102654	Quadrant — R.H.	1	0
15	908033-6	Bolt — 3/8-16 x 7/8 Nylock	3	3	68	102655	Quadrant — L.H.	0	1
16	102680	Chute Extension	1	0	69	900063-4	Bolt — 3/8-16 x 1 Carriage	2	2
16	102705	Chute Extension	0	1	70	915663-4	Nut — 3/8-16 E.S.	2	2
17	910864-4	Bolt — 5/16-18 x 5/8 Pan Head	5	5	71	102657	Lever Ass'y.	1	0
18	915662-4	Nut — 5/16-18 E.S.	5	5	71	102431	Lever Ass'y.	0	1
19	5240	Roller	1	1	72	102597	Grip	1	1
20	100284	Bushing	2	2	73	101853	Spring	1	1
21	102770	Shaft Assy. — Roller	1	1	74	102652	Support Ass'y. — Gage Wheel	1	0
22	908002-4	Bolt — 1/4-20 x 5/8	1	1	74	102418	Support Ass'y. — Gage Wheel	0	1
23	915111-6	Nut — 1/4-20 Eslok	1	1	75	102615	Bracket — Pivot	2	2
24	102773	Spring — Roller Stop	1	1	76	102618	Bar	2	2
25	6719	Pulley — Flat — Idler	1	0	77	900064-4	Bolt — 3/8-16 x 1 1/4 Carriage	4	4
25	6769	Pulley — Flat — Idler	0	1	78	915663-4	Nut — 3/8-16 E.S.	4	4
26	915663-4	Nut — 3/8-16 E.S.	1	1	79	5240	Roller Ass'y.	2	2
27	6715	Idler Support Bar Assy.	1	1	80	100284	Bushings	4	4
28	6720	Slide Block	2	2	81	920011-4	Washer — 1/2 SAE	2	2
29	6748	Slide	2	2	82	5701	E-Ring — 1/2"	2	2
30	900039-4	Bolt — 5/16-18 x 1 1/4 Carriage	3	3	83	5305	Wheel 6 x 1.75	2	2
31	900040-4	Bolt — 5/16-18 x 1 1/2 Carriage	1	1	84	5306	Bearing	4	4
32	920008-4	Washer — 5/16 SAE	5	5	85	5188	Bolt — Shoulder	2	2
33	915662-4	Nut — 5/16-18 E.S.	3	3	86	915113-6	Nut — 3/8-16 Eslok	2	2
34	915112-6	Nut 5/16-18 Eslok	2	2	87	101728	Front Support Ass'y.	1	1
35	6651	Spring	1	1	88	101763	V-Pulley	1	1
36	6747	Angle	1	0	89	101480	Bearing	2	2
37	6726	Cover — Belt	1	0	90	936029	Snap Ring	2	2
37	6770	Cover — Belt	0	1	91	101734	Spacer — Inner 5/8"	1	1
38	5924	Nut — #10-32 E.S. — Belt Cover	10	0	92	101762	Pulley — Flat	1	1
39	960150-4	Screw — 1/4-20 x 3/8 Whizlock	0	6	93	101757	Spacer — Outer 1/2"	1	1
40	6738	V-Belt	1	0	94	102582	Belt Cover Ass'y.	1	1
40	1594	V-Belt	0	1	95	102976	Nut — 3/4-16 MF	1	1
41	102742	V-Belt	1	1	96	101851	Adjusting Knob	1	1
42	101777	Bar — Draft	2	2	97	933156	Spiral Pin — 1/8 x 1	1	1
43	102958	Leveler Ass'y.	1	1	98	MW-4405	Spring Washer	1	1
44	102570	Shaft — Front	1	1	99	920009-4	Washer — 3/8 SAE	1	1
45	101758	Hitch Ass'y.	1	1	100	101842	Rod — Adjust	1	1
46	102704	Spacer	4	4	101	101708	Trunnion — Double	1	1
47	900063-9	Bolt — 3/8-16 x 1	4	4	102	100398	E-Ring — 3/8	2	2
48	102809	Nut — 3/8-16 MF Two-way Lock	4	4	103	933190	Spirol Pin — 3/16 x 1 1/4	2	2
49	102322	Bumper — Rubber	2	2	104	102601	Decal — Height Adjustment	1	1
50	900038-4	Bolt — 5/16-18 x 1 Carriage	4	4	105	102952	Decal — Mower Guard	1	1
51	915112-6	Nut — 5/16-18 Eslok	4	4	106	102962	Decal — Mower Width	1	1
52	920038-4	Washer — 5/16 SAE	4	4	107	4570	Decal — Caution	2	2
53	102430	Bracket — R.H. Rear	1	0	108	102832	Decal — Emblem	1	1
					109	9815	Decal — Belt Installation	1	1

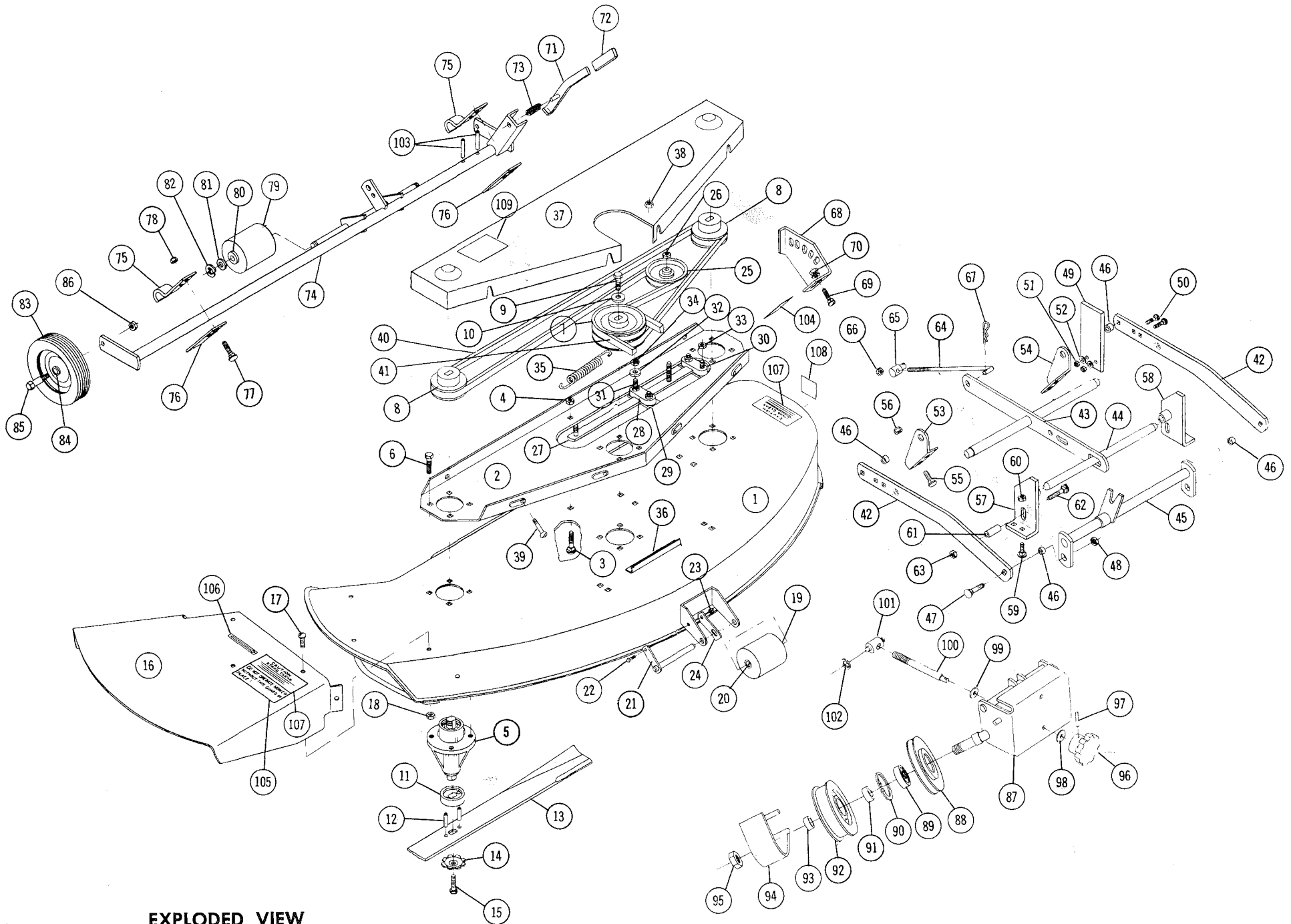

EXPLODED VIEW

## SAFETY SUGGESTIONS

Recommended by Outdoor Power Equipment Institute

### SAFE OPERATION PRACTICES — RIDING VEHICLES

1. Know the controls and how to stop quickly — **READ THE OWNER'S MANUAL.**
2. Do not allow children to operate vehicle. Do not allow adults to operate it without proper instruction.
3. Do not carry passengers. **Keep children and pets a safe distance away.**
4. Clear work area of objects which might be picked up and thrown.
5. Disengage all attachment clutches and shift into neutral before attempting to start engine (motor).
6. Disengage power to attachments and stop engine (motor) before leaving operator position.
7. Disengage power to attachment(s) and stop engine (motor) before making any repairs or adjustments.
8. Disengage power to attachments when transporting or not in use.
9. Take all possible precautions when leaving vehicle unattended; such as disengaging power-take-off, lowering attachments, shifting into neutral, setting parking brake, stopping engine and removing key.
10. Do not stop or start suddenly when going uphill or downhill. Mow up and down the face of steep slopes; never across the face.
11. Reduce speed on slopes and in sharp turns to prevent tipping or loss of control. Exercise extreme caution when changing direction on slopes.
12. Stay alert for holes in terrain and other hidden hazards.
13. Watch out for traffic when crossing or near roadways.
14. When using any attachments never direct discharge of material toward bystanders nor allow anyone near vehicle while in operation.
15. Handle gasoline with care — it is highly flammable.
  - A. Use approved gasoline container.
  - B. Never remove cap or add gasoline to a running or hot engine or fill fuel tank indoors. Wipe up spilled gasoline.
  - C. Open doors if engine is run in garage — exhaust fumes are dangerous. Do not run engine (motor) indoors.
16. Keep vehicle and attachments in good operating condition and keep safety devices in place.
17. Keep all nuts, bolts, and screws tight to be sure equipment is in safe working condition.
18. Never store equipment with gasoline in the tank inside a building where fumes may reach an open flame or spark.
19. Allow engine to cool before storing in any enclosure.
20. To reduce fire hazard keep engine free of grass, leaves or excessive grease.
21. Vehicle and attachments should be stopped and inspected for damage after striking a foreign object and the damage should be repaired before restarting and operating the equipment.
22. Do not change engine governor settings or over-speed engine.
23. When using vehicle with mower:
  - (1) Mow only in daylight or in good artificial light.
  - (2) Never make a cutting height adjustment while engine (motor) is running if operator must dismount to do so.
  - (3) Shut engine (motor) off when removing grass catcher and/or unclogging chute.
  - (4) Check blade mounting bolts for proper tightness at frequent intervals.
24. Check grass catcher bags frequently for wear or deterioration. Replace with new bags for safety protection (when so equipped).



---

Wheel Horse Service Bulletins 1961 - 1990: **#142** Issued: March 1973  
**Model 7-2611 Lawn Vacuum - Drive Belt Clearance**

[Previous](#)   [Table of Contents](#)   [Next](#)

---

FOR USE WITH 1973 MODEL 5-1010 MOWERS ONLY

ALL DISTRIBUTORS/DEALERS:

1. Problem:

1.1 Drive belt #1594 does not clear #101777 bar-draft.

2. Solution (Field):

2.1 Replace #101777 with part #104030 bar-draft.

2.2 Replace right bracket #102430 with a left bracket #102429.

3. Solution (Factory):

3.1 All shipments after this date from our plant will include bar-draft #104030 and a left bracket #102429 packaged with each Lawn-Vac.

4. Order:

4.1 Order parts in paragraph 2 from your distributor.

5. Reimbursement:

5.1 File a standard warranty claim for both parts and labor directly with us here in South Bend, our standard procedure.

5.2 Operation number 51001-A.

5.3 Labor allowance 1/2 hour-\$3.25.