

## PARTS LIST AND INSTRUCTIONS



# WHEEL HORSE

WHEEL-HORSE PRODUCTS, INC. • SOUTH BEND, IND.

## ROTARY MOWER

### MODELS

# 5-0611 & 5-0702



### DESCRIPTION

The Model 5-0611 mower is a rear discharge mower and the Model 5-0702 has a side discharge. Either mower is designed to fit 7 h.p. and 8 h.p. vertical crankshaft tractors. It is shipped completely assembled. Only the lift link location and length need be checked before the mower is installed on a tractor.

### INSTALLATION PROCEDURE

The lift link should measure  $2\frac{3}{8}$ " from the center of the bend to the face of the nut next to the lift stud. See Figure 1. Turn the nut as necessary to set the distance. This is a basic setting. After the mower is installed, the link can be shortened to provide the highest possible travel position for the mower.

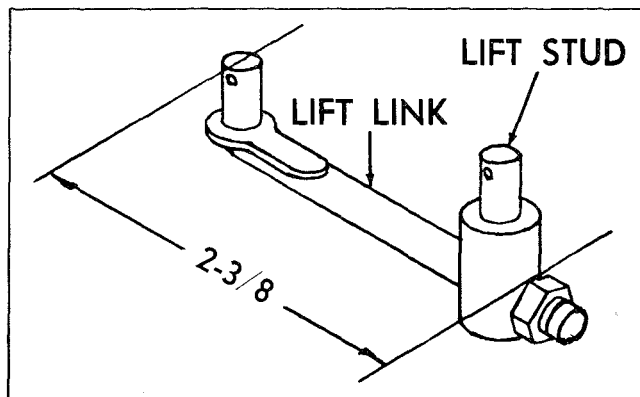

FIGURE 1

On 7 h.p. models, install the lift link in the front hole of the lift link bracket. On 8 h.p. models, install it in the rear hole. The lift stud must enter the bracket from the left side and is secured with a hairpin cotter. See Figure 2.

From beneath the tractor, feed a loop of the drive belt forward through the attachment belt guard (lower loop) which is located just to the rear of the engine pulley, and wrap it into the power take-off groove of the engine pulley (bottom groove).

Twist the left and right belt strands one-quarter turn and fit them between the belt guides and into the grooves of their respective idler pulleys. The right hand pulley is visible to the rear of the foot rest in Figure 3. Lodge the free loop of the belt temporarily up out of the way under the tractor and proceed with the mower installation.

Turn the steering wheel fully to the left. Set the mower wheels in the lowest cutting position. Slide the mower under the tractor from the right side, working it back and forth carefully to avoid damaging the idler pulley belt guides. Center the mower under the tractor.

Drop the free loop of the drive belt between the rails of the mower lift assembly. Pass it under the lift bracket, through the belt guide, and into the groove of the mower pulley.

Move the tractor lift lever forward to its lowest position. Connect the mower lift link to the lift plate of the tractor by inserting the end of the link from

the left side into the front hole of the plate. Secure it with a hairpin cotter.

Remove the hairpin cotter from one end of the attachment pivot rod, Figure 3, and withdraw the rod from the tractor frame. Raise the mower lift rails and align the pivot holes with the corresponding holes in the tractor frame. If drive belt tension makes it difficult to align the pivot rod holes, prop the attachment clutch lever at the right side of the hood stand in the raised (released) position. Reinstall the pivot rod through the tractor frame and mower lift rails and secure with a hairpin cotter.

Raise the mower to travel position. If the mower deck hangs either high or low in front, loosen the lock nut on the leveler, Figure 2, and turn the leveler in or out as necessary to make the mower deck ride level to  $\frac{1}{8}$ " low in front. Tighten the lock nut securely.

For proper tensioning of the drive belt, see tractor owners manual.

## MOWER REMOVAL

Set the mower wheels in the lowest cutting position and disengage the attachment clutch. Turn the front wheels to the extreme left and move the tractor lift lever to its lowest position. Remove the hairpin cotter from one end of the attachment pivot rod and withdraw it from the tractor frame. This will drop the mower lift rails. Reinstall the attachment pivot rod in the tractor frame and secure with a hairpin cotter.

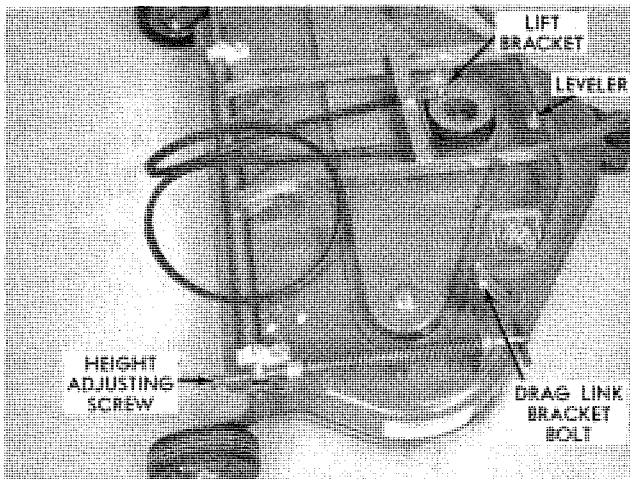

FIGURE 2

Remove the hairpin cotter and disengage the lift link from the tractor lift plate. Roll the mower a little to the rear and disengage the drive belt from the mower pulley. Withdraw the belt from the belt guide on the mower lift assembly. Slide the mower carefully to the right and out from under the tractor.

## OPERATION

1. Lift the mower with the tractor lift lever to remove weight of the mower from the gauge wheels.  
**Note:** Never stand on the mower.

2. Turn the height adjusting screw to raise or lower the gauge wheels to the desired cutting height (see decal on mower deck). The recommended cutting height is two to three inches.

3. Disengage the attachment clutch by lifting the lever on the right side of the hood stand and lower the mower before starting the tractor engine.

4. Start the engine and slowly engage the attachment clutch. For best cutting results on average level lawns, operate the tractor at full throttle in 2nd gear with a mechanical transmission or half speed (approx.  $2\frac{1}{2}$  m.p.h.) with an automatic transmission. If ground speed is too fast, mowing will be uneven because the mower blades will not have time to lift each blade of grass into cutting position.

5. To mow extra tall grass or grass containing lots of moisture, raise the mower to the highest position for the first cut using the lowest drive speed. Then recut to normal height.

## MAINTENANCE

The mower requires no lubrication except the wheels which have grease gun fittings.

### Blade Maintenance:

Invert the mower. Remove the three blade attaching bolts and special washers. Lift the blades off the spindles.

File or grind the blades evenly, taking care to retain the original cutting edge angle and blade balance.

Reinstall the blades, making sure the pins protruding from the spindle cups engage the blades properly. The side of the blade with the lift area (turned up section) must be installed facing the mower deck. Tighten the blade attaching screws to a torque of 35 Ft./Lbs. These screws, Part No. 908033-6 should be replaced after every two or three times they are removed and reinstalled.

### Mower Belt Replacement:

Remove the drag link bracket bolts, Figure 2, at the R.H. and L.H. mower deck brackets and remove the lift assembly from the mower. Remove the belt cover nuts and lift the cover off the mower deck.

Remove the old belt and install the new belt in accordance with the belt diagram decal on the belt cover. Reinstall the belt cover and lift assembly.

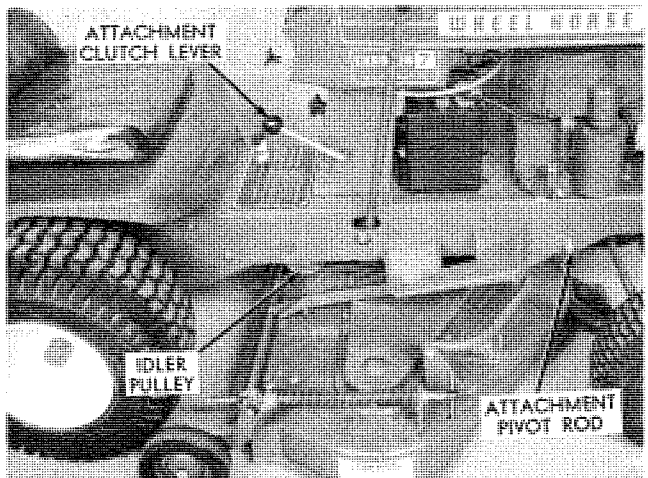

FIGURE 3

## PARTS LIST FOR 5-0611 & 5-0702 ROTARY MOWERS

When ordering parts always list Part No. and name of Part.

Parts available only through Authorized Dealers.

(Specifications subject to change without notice.)

Item No.	Part No.	Description	No. Req'd.	Item No.	Part No.	Description	No. Req'd.
1	100471	Deck — Mower (Model 5-0611)	1	39	933188	Rollpin $\frac{3}{16}$ x 1	2
2	8389	Housing — Bearing	3	40	900064-4	Bolt Carriage $\frac{3}{8}$ -16 x $1\frac{1}{4}$	2
3	103119	Bearing — Integ. Shaft	3	41	932009-4	Cotter Pin $\frac{3}{32}$	1
4	900234-4	Bolt — Carriage $\frac{3}{8}$ -16 x 1	12	42	5305	Wheel (5306 Bushing)	2
5	915113-6	Nut — Eslök $\frac{3}{8}$ -16	14	43	5188	Bolt — Shoulder	2
6	5240	Roller & Bearings	1	44	8870	Trunnion	1
7	1970	Bearing — Nylon	2	45	920011-4	Washer — $\frac{1}{2}$ SAE	3
8	102770	Roller Shaft Ass'y.	1	46	100474	Crank	1
9	102773	Spring	1	47	5951	Washer — Double D	3
10	101849	Pulley — Middle Drive	1	48	915238-4	Nut Jam $\frac{1}{2}$ -13	2
11	101231	Pulley — End	2	49	8409	Bracket L.H.	1
12	2844	Washer — Special	2	50	8408	Bracket R.H.	1
13	908032-6	Bolt Hex $\frac{3}{8}$ -16 x $\frac{3}{4}$ Nylok	2	51	900063-4	Bolt Carriage $\frac{3}{8}$ -16 x 1	6
14	102780	Drive — Blade	3	52	933184	Spirol Pin $\frac{3}{16}$ x $\frac{3}{4}$	2
15	933210	Rollpin $\frac{1}{4}$ x $\frac{5}{8}$	6	53	100477	Bracket	1
16	*8393	Blade 14" — Center (Model 5-0611)	1	54	100478	Spring	1
17	*8394	Blade 12" (Model 5-0611)	2	55	102972	Bolt — Lock $\frac{3}{8}$ -16 x $\frac{7}{8}$	1
18	1336	Washer — Dome	4	56	2138	Spacer	2
19	908033-6	Bolt Hex $\frac{3}{8}$ -16 x $\frac{7}{8}$ Nylok	4	57	908035-4	Bolt Hex $\frac{3}{8}$ -16 x $1\frac{1}{4}$	2
20	102962	Decal — Mower Width	1	58	7932	Cover — Belt	1
21	8690	Bar Idler Support	1	59	100411	Guide — Belt	1
22	7434	Pulley — Flat Idler	1	60	102961	Extension — Chute (Model 5-0611)	1
23	6720	Block — Slide	2	61	900036-4	Bolt — Carriage $\frac{5}{16}$ -18 x $\frac{5}{8}$	1
24	915236-4	Nut $\frac{3}{8}$ -16 Jam	3	64	910837-4	Screw — Machine $\frac{1}{4}$ -20 x $\frac{5}{16}$	2
25	900039-4	Bolt Carriage $\frac{5}{16}$ -18 x $1\frac{1}{4}$	3	65	915661-4	Nut Elastic Stop $\frac{1}{4}$ -20	2
26	900040-4	Bolt $\frac{5}{16}$ -18 x $1\frac{1}{2}$ Carriage	1	66	5924	Nut Elastic Stop #10-32	7
27	915112-6	Nut $\frac{5}{16}$ -18 Eslök	6	67	920007-4	Washer $\frac{1}{4}$ SAE	2
28	920008-4	Washer $\frac{5}{16}$ SAE	6	68	9200	Link — Lift	1
29	6651	Spring	1	69	9808	Stud — Lift	1
30	6748	Slide	2	70	933504-4	Hairpin Cotter	2
31	100618	Mower Lift	1	71	8411	Belt 77" Mower	1
32	100087	Leveler — Mower	1	72	8412	Belt 86" Drive	1
33	100476	Height Control Bracket	1	73	100479	Decal — Height Adjustment	1
34	8406	Support	2	74	8413	Decal — Belt Installation	1
35	8407	Clip	2	75	4570	Decal — Caution	2
36	900067-4	Bolt Carriage $\frac{3}{8}$ -16 x 2	2	76	103090	Deck — Mower (Model 5-0702)	1
37	920009-4	Washer $\frac{3}{8}$ SAE	7	77	**100460	Blade 14" — Center (Model 5-0702)	1
38	915663-4	Nut Elastic Stop $\frac{3}{8}$ -16	11	78	**100459	Blade 12" (Model 5-0702)	2

\* Order Part No. 9819 (3-Blade Kit)

\*\* Order Part No. 101093 (3-Blade Kit)

EXPLODED VIEW

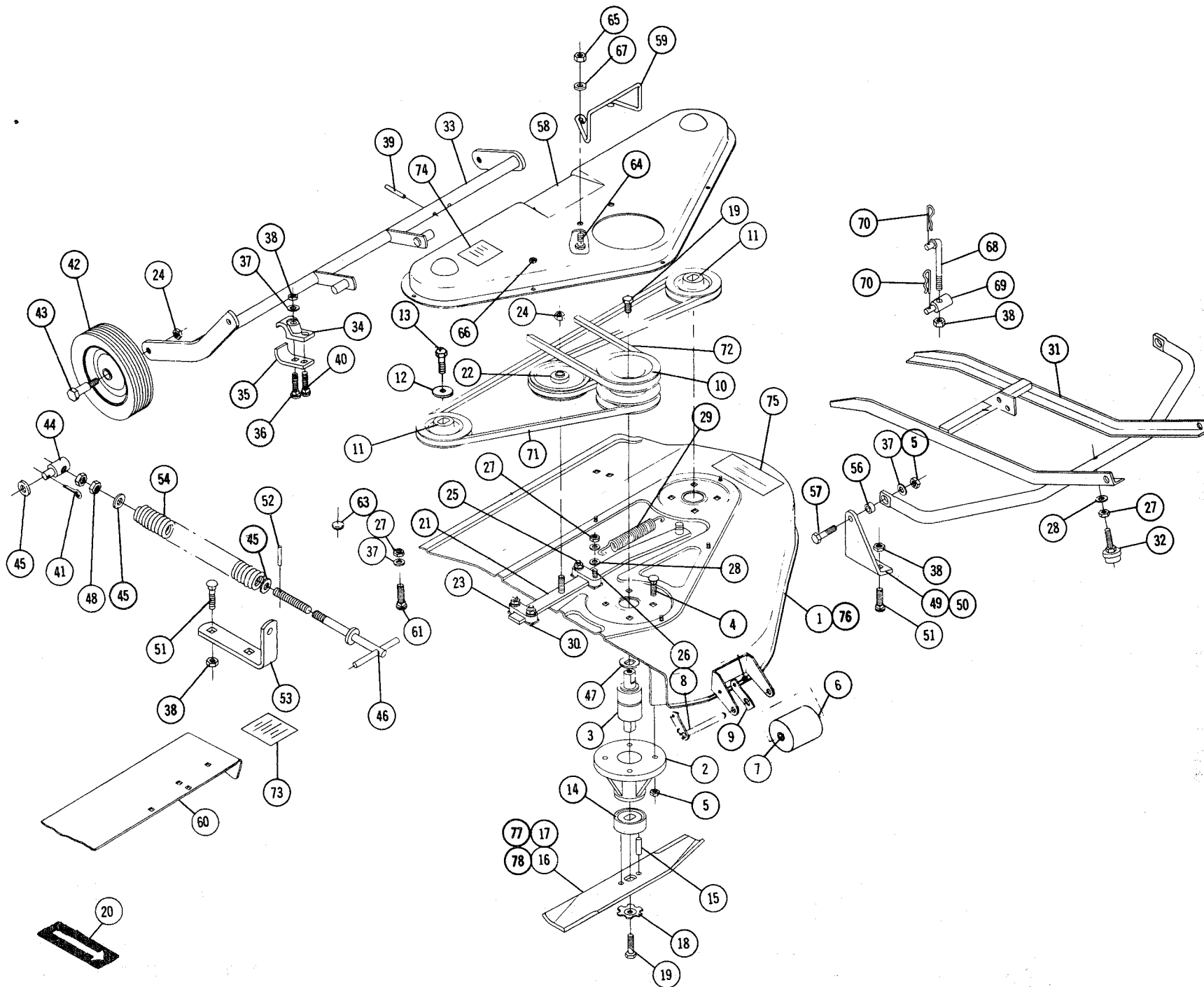

# SAFETY SUGGESTIONS

Recommended by Outdoor Power Equipment Institute

## SAFE OPERATION PRACTICES — RIDING VEHICLES

1. Know the controls and how to stop quickly — **READ THE OWNER'S MANUAL.**
2. Do not allow children to operate vehicle. Do not allow adults to operate it without proper instruction.
3. Do not carry passengers. **Keep children and pets a safe distance away.**
4. Clear work area of objects which might be picked up and thrown.
5. Disengage all attachment clutches and shift into neutral before attempting to start engine (motor).
6. Disengage power to attachments and stop engine (motor) before leaving operator position.
7. Disengage power to attachment(s) and stop engine (motor) before making any repairs or adjustments.
8. Disengage power to attachments when transporting or not in use.
9. Take all possible precautions when leaving vehicle unattended; such as disengaging power-take-off, lowering attachments, shifting into neutral, setting parking brake, stopping engine and removing key.
10. Do not stop or start suddenly when going uphill or downhill. Mow up and down the face of steep slopes; never across the face.
11. Reduce speed on slopes and in sharp turns to prevent tipping or loss of control. Exercise extreme caution when changing direction on slopes.
12. Stay alert for holes in terrain and other hidden hazards.
13. Watch out for traffic when crossing or near roadways.
14. When using any attachments never direct discharge of material toward bystanders nor allow anyone near vehicle while in operation.
15. Handle gasoline with care — it is highly flammable.
  - A. Use approved gasoline container.
  - B. Never remove cap or add gasoline to a running or hot engine or fill fuel tank indoors. Wipe up spilled gasoline.
  - C. Open doors if engine is run in garage — exhaust fumes are dangerous. Do not run engine (motor) indoors.
16. Keep vehicle and attachments in good operating condition and keep safety devices in place.
17. Keep all nuts, bolts, and screws tight to be sure equipment is in safe working condition.
18. Never store equipment with gasoline in the tank inside a building where fumes may reach an open flame or spark.
19. Allow engine to cool before storing in any enclosure.
20. To reduce fire hazard keep engine free of grass, leaves or excessive grease.
21. Vehicle and attachments should be stopped and inspected for damage after striking a foreign object and the damage should be repaired before restarting and operating the equipment.
22. Do not change engine governor settings or over-speed engine.
23. When using vehicle with mower:
  - (1) Mow only in daylight or in good artificial light.
  - (2) Never make a cutting height adjustment while engine (motor) is running if operator must dismount to do so.
  - (3) Shut engine (motor) off when removing grass catcher and/or unclogging chute.
  - (4) Check blade mounting bolts for proper tightness at frequent intervals.
24. Check grass catcher bags frequently for wear or deterioration. Replace with new bags for safety protection (when so equipped).



